

## C550

### 6 - 10kVA Online double conversion

**Suggested applications:** Servers rooms and small data centre environments

The C550 can be installed with internal batteries as standard. This removes the need for external battery cabinets on standard run times, enabling you to maximise valuable floor space.

#### Key Features

- Wide input voltage window
- Selectable output voltage
- Frequency converter feature
- EPO connection
- Future expansion or redundancy
- Plug n play parallel kits
- Internal manual bypass
- Small footprint

**TECHNOLOGY:** C550, 10kVA     **APPLICATION:** NHS RECOVERY WARDS

**OBJECTIVE:** TO PROVIDE CRITICAL POWER BACKUP



Parallel connection



Additional battery connection



Smart phone app monitoring



High efficiency



Virtualisation compatible



Intelligent communication slot



Online double conversion



Pure sinewave output



USB connectivity & HID compatible



ECO mode function



\*Image shows 10kVA C550

RATING	C550-060-B	C550-060-C	C550-100-B	C550-100-C
Dimensions WxDxH (mm)	220x492x589	220x492x348	220x492x589	220x452x348
Weight (Kg)	53	14	61	16
<b>INPUT</b>				
Voltage	220/230/240/250VAC			
Voltage tolerance/range	176 - 276VAC 100% load; 120 - 264 VAC 60% load			
Frequency	45-55Hz/54-66Hz			
Frequency tolerance/range	±10%			
<b>OUTPUT</b>				
Power factor	1			
Waveform	Sinewave			
Voltage	208/220/230/240V			
Frequency	45-55/54-66Hz			
Efficiency (%)	>98%			
<b>BATTERY</b>				
DC voltage (VDC)	192Vdc/240Vdc			
Charger capacity (Ah)	0-4	0-12	0-4	0-12
<b>MECHANICAL</b>				
Output connection	Hardwired terminal			
<b>ENVIRONMENTAL</b>				
Operating temperature tolerance	0-40 °C			
Storage temperature tolerance	-15-40 °C			
Relative humidity	<0-95% (non-condensing)			
Operating altitude tolerance	<1000m			
<b>FEATURES</b>				
Communication	emergency power off, dry in and dry out, RS-232, USB			
Optional comms	SNMP/MODBUS/dry contact			
Parallel	Optional			
Options & functions	Intelligent card			

Full technical specification and product information can be found at [www.certaups.com](http://www.certaups.com)

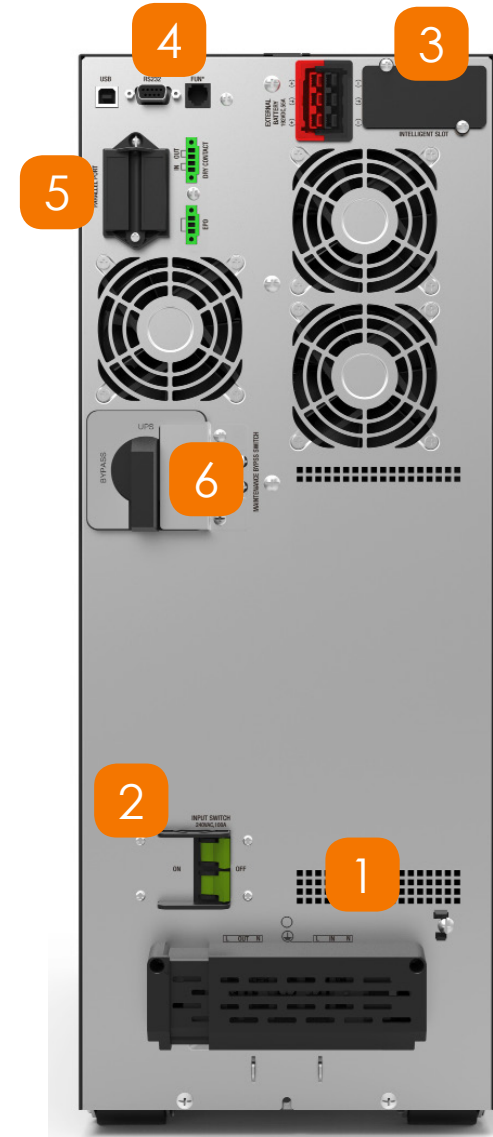

\*Image shows rear of 10kVA C550

- |                             |                       |
|-----------------------------|-----------------------|
| 1. Input / output terminals | 4. USB / RS232        |
| 2. Input breakers           | 5. Parallel port      |
| 3. Intelligent port         | 6. Maintenance bypass |

**CertaUPS**

## C550/C550R



**Tower 6-10K**

**RT 6-10K**

**Installation/Manual**

# CertaUPS

**Service and support**

[WWW.CERTAUPS.COM](http://WWW.CERTAUPS.COM)

[INFO@CERTAUPS.COM](mailto:INFO@CERTAUPS.COM)

**T: +44 (0)1246 431 431**



Additional  
Battery  
connection



Eco-mode  
function



Parallel  
connection



High  
efficiency  
up to 97%



Intelligent  
communications



Maintenance  
bypass  
switch



Virtualisation  
compatible



PF=1  
Unity power  
factor



Pure  
sinewave  
output



Smart app  
monitoring



USB  
connectivity  
& ITD support



Online double  
conversion

## SAFETY INSTRUCTIONS

**SAVE THESE INSTRUCTIONS.** This manual contains important information that should be followed during the installation and maintenance of the UPS, batteries and battery cabinet.

The C500® G2 models covered in this manual are intended for installation in an environment between below 0 to 50°C, free of conductive contaminants and less than 1000m altitude.

### Certification standards

- Safety: IEC/EN 62040-1
- EMC: IEC/EN 62040-2
- Performance: IEC/EN 62040-3
- IEC 61000-4-2 (ESD): level 4.
- IEC 61000-4-3 (RS): level 3.
- IEC 61000-4-4 (EFT): level 4.
- IEC 61000-4-5 (Surge): level 4.
- IEC 61000-4-6 (CS): level 3.
- IEC 61000-4-8 (Magnetic Field): level 4.

### Special symbols

The following are examples of symbols which feature on the UPS or accessories to alert you to important information:



**RISK OF ELECTRIC SHOCK** - Observe the warning associated with the risk of electric shock.



Important instructions that must always be followed.



Do not dispose of the UPS or the UPS batteries in general waste.

This product contains sealed lead acid batteries and must be disposed as is explained in this manual. For more information, contact your local recycling or hazardous waste center.



This symbol indicates that you should not discard waste electrical or electronic equipment (WEEE) in general waste. For proper disposal, contact your local recycling or hazardous waste center.



Information, advice, help.



Refer to the user manual of UPS accessories.

---

## Personal Safety

- RISK OF VOLTAGE BACKFEED. The system has its own power source (the batteries). Isolate the UPS and check for hazardous voltage upstream and downstream during operation. **Terminal blocks may be energized even if the system is disconnected from the AC power source.**
- Dangerous voltage levels are present within the system. It should be opened exclusively by qualified service personnel.
- The system must be properly grounded.
- The batteries supplied within the system contain small amounts of toxic materials. To avoid accidents, the directives listed below must be observed:
  - Servicing of batteries should be performed or supervised by personnel knowledgeable about batteries and the required safety precautions.
  - When replacing batteries, replace with the same type and number of batteries or battery packs.
  - Do not dispose of batteries in a fire. The batteries may explode.
  - Batteries constitute potential danger via electrical shock or burns. The short-circuit current could be extremely high.
- Precautions must be taken whenever handling batteries:
  - Wear rubber gloves and boots.
  - Do not lay tools or metal components on top of batteries.
  - Disconnect charging source prior to connecting or disconnecting battery terminals.
  - Determine if batteries are inadvertently grounded. If inadvertently grounded, remove source from ground. Contact with any part of a grounded battery can result in electrical shock. The likelihood of this occurring can be reduced if such grounds are removed during installation and maintenance (applicable to equipment and remote battery supplies not having a grounded supply circuit).

---

## Product safety

- The UPS connection procedures and operational instructions described within this manual must be followed in the indicated order.
- An additional circuit breaker with breaking capacity 6kA shall be used between power source and input when installation this unit
- CAUTION - To reduce the risk of fire, the unit connects only to a circuit provided with branch circuit overcurrent protection for :  
63A rating, for 6kVA models,  
100A rating, for 10kVA models  
The upstream circuit breaker for Normal AC/Bypass AC must be easily accessible. The unit can be disconnected from AC power source by opening this circuit breaker.
- An additional AC contactor is used for back feed protection and must comply with IEC/EN 62040-1 (the creep age and clearance distances shall meet the basic insulation requirements for pollution degree 2).
- Disconnection and overcurrent protection devices shall be provided by others for permanently connected AC input (Normal AC/Bypass AC) and AC output circuits.
- Check that the indications on the rating plate correspond to your AC powered system and to the actual electrical consumption of all the equipment to be connected to the system.
- For PLUGGABLE EQUIPMENT, the socket-outlet shall be installed near the equipment and shall be easily accessible
- Never install the system near potential liquid hazards or in an excessively damp/humid environment.
- Never let foreign objects enter the UPS system.
- Do not house within and enclosed space to ensure adequate ventilation and proper heat dissipation
- Never expose the system to direct sunlight or source of heat.
- If the system must be stored prior to installation, storage must be in a dry place.
- The admissible storage temperature range is -25°C to +60°C with battery (-15°C to +40°C without battery).

---

## Special precautions

- The unit is heavy: wear safety shoes and ideally use a vacuum lifter for handling safety.
- All handling operations will require at least two people (unpacking, lifting, installation within a rack system).
- **Straps are provided only for removing the UPS from its packaging (do not use the straps to carry the unit) improper handling may cause personal injury and/or damage to the UPS.**
  - keep 12in / 30cm minimum distance between the straps
  - lift the unit carefully and keep it at low height
  - keep the unit horizontal during unpacking.
- If the UPS is to remain unpowered for an extended period, the UPS must be energized for a minimum period of 24 hours at least once every 6 months (for a normal storage temperature less than 25°C). This charges the battery, avoiding possible irreversible damage.
- During the replacement of the Battery Module, it is imperative to use the same type and number of element as the original Battery Module provided with the UPS to maintain operational performance and safety.

## Contents

<b>1. INTRODUCTION .....</b>	<b>0</b>
1.1 ENVIRONMENTAL PROTECTION .....	0
<b>2. PRESENTATION .....</b>	<b>2</b>
<b>3. INSTALLATION .....</b>	<b>6</b>
3.1 INSPECTING THE EQUIPMENT.....	6
3.2 UNPACKING THE UNIT .....	6
3.3 CHECKING THE ACCESSORY KIT.....	7
3.4 INSTALL THE UPS.....	8
3.5 INSTALL AND CONNECT EBM TO UPS .....	10
<b>4. POWER CABLES CONNECTION .....</b>	<b>13</b>
4.1 ACCESS TO TERMINAL BLOCKS.....	13
4.2 PARALLEL SET UP .....	14
<b>5. OPERATION .....</b>	<b>15</b>
5.1 CONTROL PANEL .....	15
5.2 LCD DESCRIPTION.....	16
5.3 DISPLAY FUNCTIONS .....	19
5.4 USER SETTINGS .....	20
5.5 UPS STARTUP AND SHUTDOWN .....	21
5.6 LCD OPERATION.....	22
<b>6. COMMUNICATION.....</b>	<b>29</b>
6.1 COMMUNICATION PORTS .....	29
6.2 NETWORK MANAGEMENT CARD (OPTIONAL) .....	30
6.3 UPS MANAGEMENT SOFTWARE.....	31

---

<b>7. UPS MAINTENANCE</b> .....	<b>32</b>
7.1 EQUIPMENT CARE .....	32
7.2 TRANSPORTING THE UPS .....	32
7.3 STORING THE EQUIPMENT .....	32
7.4 REPLACING BATTERIES.....	33
7.5 RECYCLING THE USED EQUIPMENT.....	35
<b>8. TROUBLESHOOTING</b> .....	<b>35</b>
8.1 TYPICAL ALARMS AND FAULTS .....	36
8.2 SILENCING THE ALARM.....	40
<b>9. SPECIFICATIONS</b> .....	<b>41</b>
9.1 MODEL SPECIFICATIONS .....	41
<b>10 GLOSSARY</b> .....	<b>46</b>

## 1. Introduction

Thank you for selecting C500® G2 UPS to protect your electrical equipment. The C500® G2 UPS has been designed with the utmost care.

We recommend that you take the time to read this manual to take full advantage of the many features of your UPS (Uninterruptible Power System).

Before installing your C500® G2 UPS, please read the booklet including the safety instructions. Then follow the instructions within this manual.

### 1.1 Environmental protection

Products are developed with an environmentally friendly design approach.

#### Substances

This product does not contain CFCs, HCFCs or asbestos.

#### Packing

To improve waste treatment and facilitate recycling, separate the various packaging components.

- The cardboard we use comprises of over 50% of recycled cardboard.
- Sacks and bags are made of polyethylene.
- Packing materials are recyclable and bear the appropriate identification

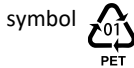

Materials	Abbreviations	Number in the symbols 
Polyethylene terephthalate	PET	01
High-density polyethylene	HDPE	02
Polyvinyl chloride	PVC	03
Low-density polyethylene	LDPE	04
Polypropylene	PP	05
Polystyrene	PS	06

Follow all local regulations for the disposal of packing materials.

---

## Product

The product is made up of recyclable materials.

Dismantling and destruction must take place in compliance with all local regulations concerning waste disposal. At the end of its service life, the product must be transported to a processing center for electrical and electronic waste.

### **Battery**

The product contains lead-acid batteries that must be processed according to applicable local regulations concerning batteries.

The battery may be removed to comply with regulations and responsibly disposed of.

The C500® G2 uninterruptible power system (UPS) protects your sensitive electronic equipment from the most common power problems, including power failures, power sags, power surges, brownouts, line noise, high voltage spikes, frequency variations, switching transients, and harmonic distortion.

Power outages can occur when you least expect it and power quality can be erratic. These power problems have the potential to corrupt critical data, destroy unsaved work sessions, and damage hardware - causing hours of lost productivity and expensive repairs.

With the C500® G2, you can safely eliminate the effects of power disturbances and protect the integrity of your equipment. Providing outstanding performance, reliability and protection.

The C500® G2's unique benefits include:

- True online double-conversion technology with high power density, utility frequency independence, and generator compatibility.
- Selectable High Efficiency mode of operation.
- Standard communication options: one RS-232 communication port, one USB communication port, one dry in port and dry out port.
- Optional connectivity cards with enhanced communication capabilities.
- Firmware that is easily upgradable without a service call.

## 2. Presentation

Front panel



## Rear panels

### TOWER model

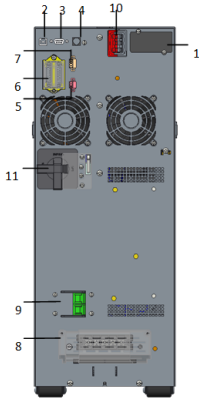

INNOVA G2 Tower 6K

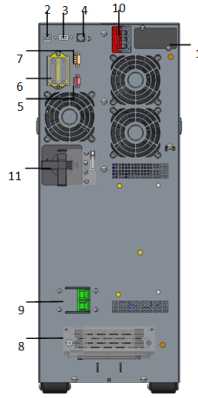

INNOVA G2 Tower 10K

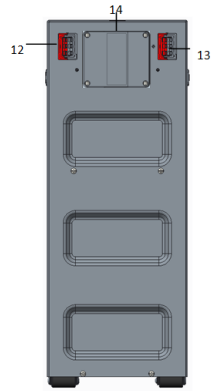

INNOVA G2 Tower EBM

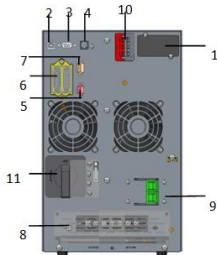

INNOVA G2 Tower 6KS

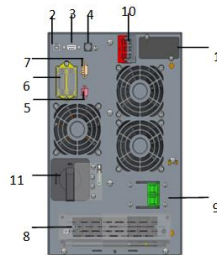

INNOVA G2 Tower 10KS

- |   |  |
|---|--|
| <ol style="list-style-type: none"> <li>1. Intelligent Expansion slot</li> <li>2. USB</li> <li>3. RS232</li> <li>4. RJ11 (only for RT model)</li> <li>5. EPO</li> <li>6. PARALLEL card (optional)</li> <li>7. DRY IN/OUT</li> <li>8. Input /Output terminal<br/>(Standard model 5pole, IPL,<br/>IPN, PE, OPL, OPN; long<br/>backup model has 2 version,<br/>one is 5 Pole. Another is</li> </ol> | <ol style="list-style-type: none"> <li>7pole. 7pole add bat+, bat-,<br/>and no external battery<br/>connector #10.)</li> <li>9. Input switch</li> <li>10. External battery connector</li> <li>11. Maintenance bypass switch<br/>(optional)</li> <li>12. EBM connector</li> <li>13. EBM connector</li> <li>14. Fuse board cover (replace<br/>EBM fuse)</li> </ol> |
|---|--|

## RT model

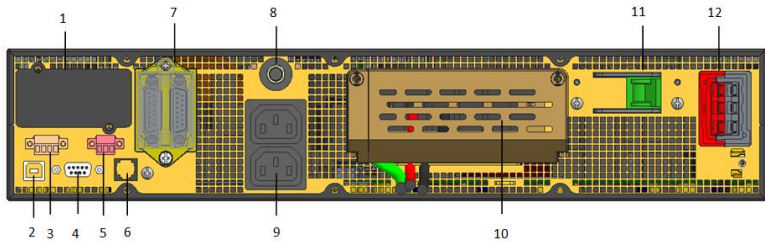

RT and Rack UPS model 6K(s) & 10K(s)

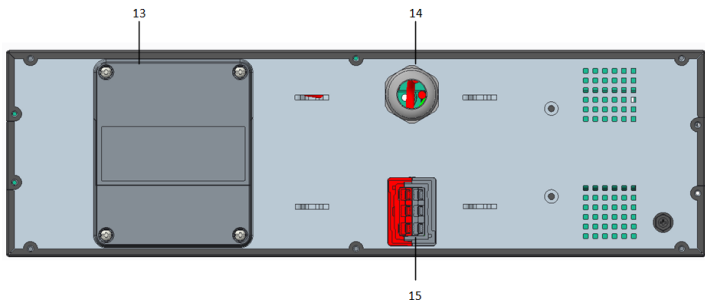

RT EBM model

- |  |  |
|--|--|
| 1. Intelligent Expansion slot                  | 10. Input /Output terminal<br>(4pole IPL, IPN, OPL, OPN. PE is<br>screw) |
| 2. USB   | 11. Input breaker (optional)   |
| 3. DRY IN/OUT                                  | 12. EBM connector  |
| 4. RS232                                       | 13. Fuse board cover (replace<br>EBM fuse)                               |
| 5. EPO   | 14. EBM plug   |
| 6. RJ11 (connect to PDU, only<br>for RT model) | 15. EBM connector  |
| 7. PARALLEL card (optional)                    |  |
| 8. Output breaker                              |  |
| 9. Output socket                               |  |

## Circuit diagram

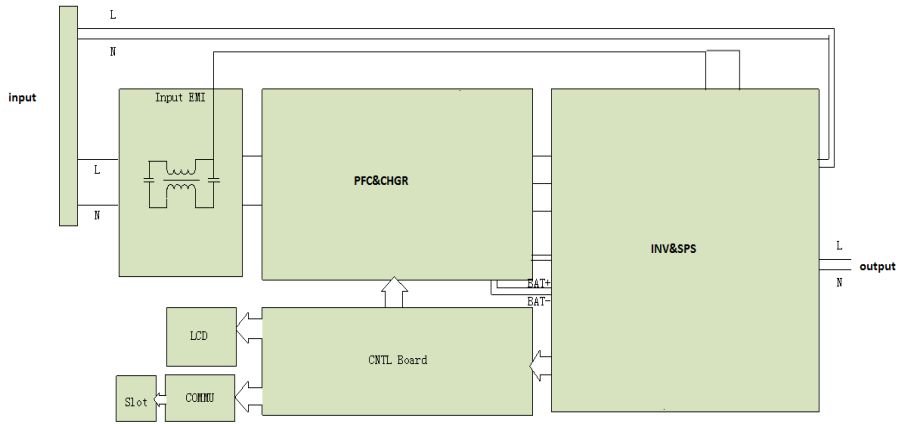

## 3. Installation

### 3.1 Inspecting the equipment

If any equipment has been damaged during shipment, keep the packing materials for the carrier or place of purchase and file a claim for shipping damage. If you discover damage after acceptance, file a claim for concealed damage.



Check the battery recharge date on the shipping carton label. If the date has passed and the batteries were never recharged, do not use the UPS. Contact your service representative.

### 3.2 Unpacking the Unit



- Unpacking the unit in a low-temperature environment may cause condensation to occur in and on the cabinet. Do not install the cabinet until the inside and outside of the cabinet are absolutely dry (hazard of electric shock).
- The cabinet is heavy (see page 42). Follow Special precautions provided on the carton.

Unpack the equipment and remove all the packing materials and shipping carton.

**Note:** Do not lift the unit's front panel and rear panel.

#### Tower model:

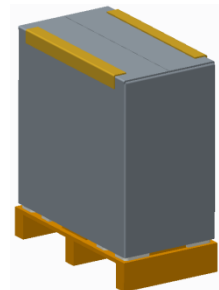
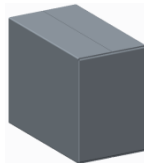
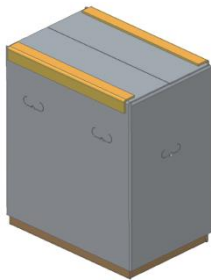

## Rack model:

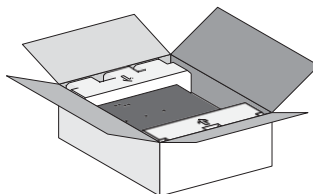
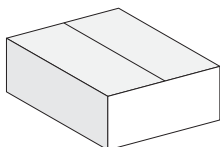

Discard or recycle the packaging in a responsible manner, or store it for future use.

Place the cabinet in a protected area that has adequate airflow and is free of humidity, flammable gas, and corrosion.



Packing materials must be disposed of in compliance with all local regulations concerning waste. Recycling symbols are printed on the packing materials to facilitate sorting.

### 3.3 Checking the accessory kit

Verify that the following additional items are included with the unit:

	Battery power cable	USB communication cable	Dry contractor	EPO contractor	Stabilizer bracket	Extension plate of Stabilizer bracket	Ear bracket	Rail kit
Tower UPS 6K/10K		X	X		X			
Tower UPS 6KS/10KS		X	X					
Tower EBM	X				X			
RT UPS 6K/10K		X	X		X		X	
RT UPS 6KS/10KS		X	X		X		X	
RT EBM						X	X	



*If you ordered other accessories, refer to specific user manuals to check the packing contents.*

## 3.4 Install the UPS

### Tower model installation:

Place the unit on a flat, stable surface in its final location.

Always keep 150 mm of free space behind the rear panel.

If installing additional unit, place them next to the first unit in their final location.

If installing Stabilizer bracket, place 4pcs bolts to the final location previously.

Bolt's position is as below.

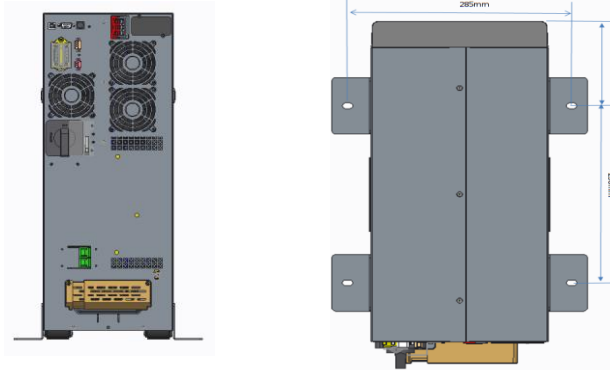

### RT model installation:

Rack position installing

1. Install Ear bracket to the unit.



2. Install the unit to rack cabinet in a suitable U-space (Previously install Rail kit refer to its user manual).

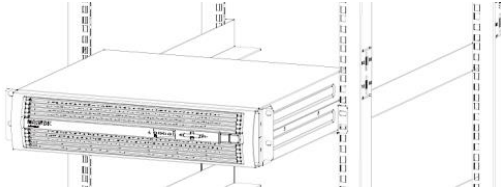

## Tower position installing

1. Rotate the LCD model to tower direction

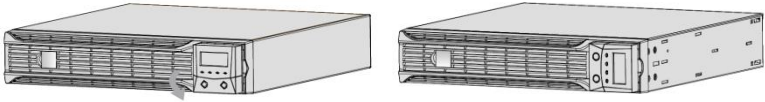

2. Set up the Stabilizer bracket as below.

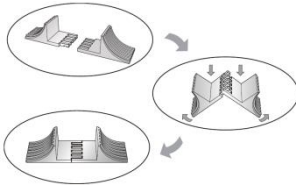

3. Take the unit to Stabilizer bracket.

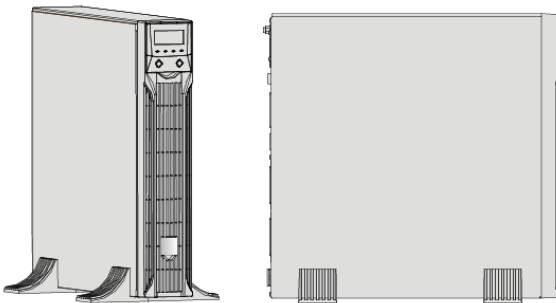

## 3.5 Install and connect EBM to UPS

### Tower EBM installation:

1. Place the unit on a flat, stable surface in its final location.
2. If installing Stabilizer bracket, place 4pcs bolts to the final location previously.  
Bolt's position is as below.

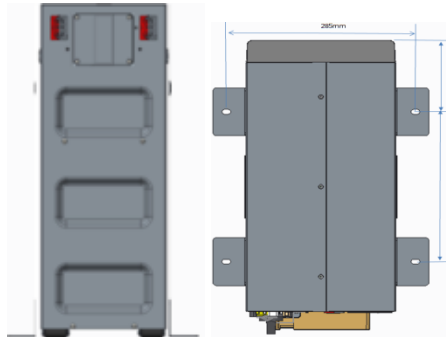

3. Connect to UPS with Battery power cable.

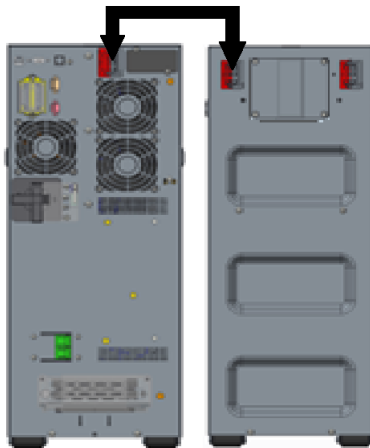

## RT EBM installation:

### Rack position installing

1. Install the Ear brackets to both sides of the unit.

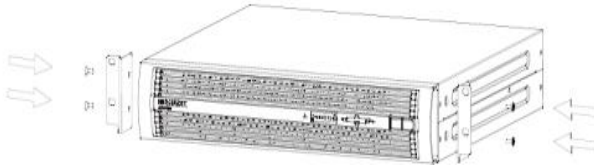

2. Mount the ups within a 19" rack cabinet in a suitable space utilizing the appropriate rail kit (refer to separate rail kit instructions).

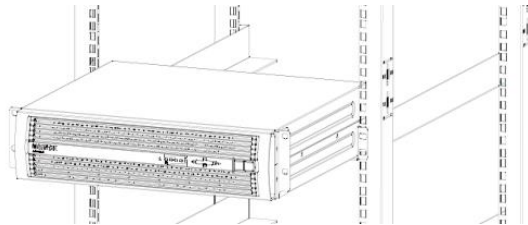

3. Connect to UPS with Battery power cable.

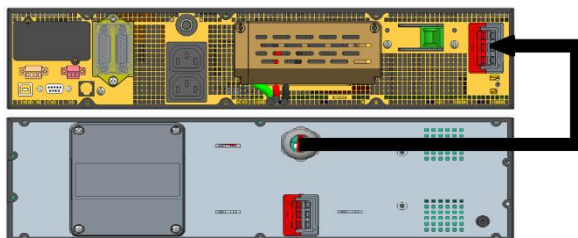

## Tower position installing

1. Set up the Extension plate as below and install to Stabilizer bracket from UPS.



2. Take the unit to Stabilizer bracket.

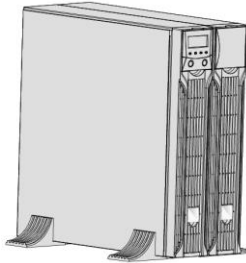

3. Connect to UPS with Battery power cable.



4. If installing additional unit, place to left and connect the right unit in their final location.

## 4. Power cables connection

Recommended protective devices and cable cross-sections

Recommended upstream protection

UPS power rating	Upstream circuit
6000VA	D curve – 63A
10000VA	D curve – 100A

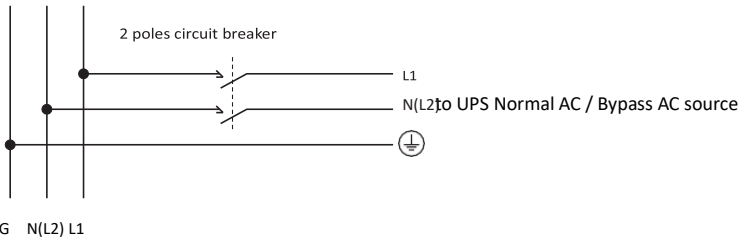

Read the Safety instructions on page 3 regarding back-feed protection requirements.

Recommended cable cross-sections

Model	6K	10K
<b>Protective earthing conductor Min cross section</b>	6mm <sup>2</sup> (8AWG)	10mm <sup>2</sup> (6AWG)
<b>Input L, N, G Min conductor cross section</b>	6mm <sup>2</sup> (8AWG)	10mm <sup>2</sup> (6AWG)
<b>Input fuse</b>	80A	100A
<b>Output L,N, Min conductor cross section</b>	6mm <sup>2</sup> (8AWG)	10mm <sup>2</sup> (6AWG)

### 4.1 Access to terminal blocks

Remove the terminal blocks cover (two screw)



High leakage current:  
Earth connection essential before connecting supply.

Common input/output sources connection



This type of connection must be carried out by qualified electrician.

Before carrying out any connection check that the upstream protection devices (Normal AC source and Bypass AC source) are open "O" (Off).

Always connect the ground wire first

1. Connect the AC cable to terminal blocks as indicator on rear panel

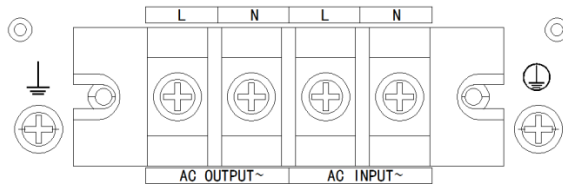

2. Install back the TB Cover

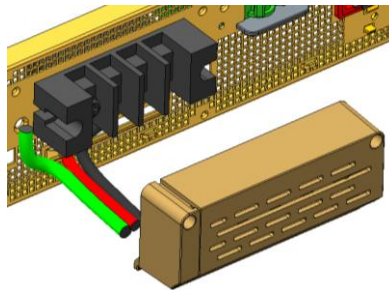

## 4.2 Parallel set up

1. Remove the parallel kit and insert the parallel PCB.

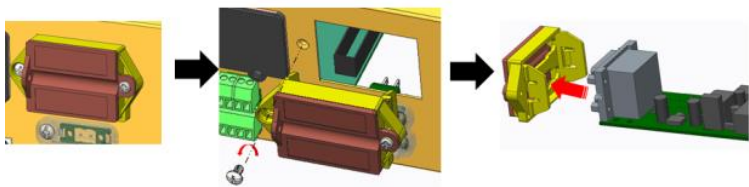

2. Install parallel kit back to the unit and insert the parallel cable

3. Re-install cover to the kit to secure the plug connection and prevent damage.

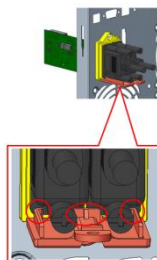

## 5. Operation

### 5.1 Control panel

The UPS has a five-button graphical LCD. It provides useful information about the UPS itself, load status, events, measurements and settings.

The following table shows the indicator status and description:



Indicator	Status	Description
Normal (Green)	On	The UPS is operating normally on Online or on High Efficiency mode.
Battery (Orange)	On	The UPS is on Battery mode.
Bypass (Orange)	On	The UPS is on Bypass mode.
	Flash	The UPS is on Standby mode.
Fault (Red)	On	The UPS has an active alarm or fault. See trouble-shooting on page 36 for additional information.

## 5.2 LCD description

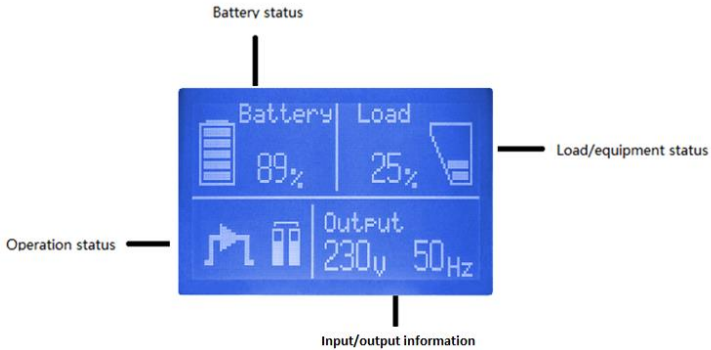

The LCD backlight automatically dims after 2 minutes of inactivity (except when a fault is present). Press any button to restore the screen.





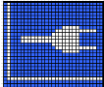
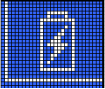

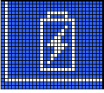
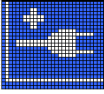
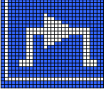
The following table describes the status information provided by the UPS

Note: If other indicator appears, see troubleshooting for additional information.

Operation status	Cause	Description
Standby mode 	The UPS is Off.	UPS is operating without output.
Online mode 	The UPS is operating normally.	The UPS is powered and protecting the equipment.
Battery mode 	A utility failure has occurred and the UPS is on Battery mode.	The UPS is powering the equipment with battery power. Prepare your equipment for shutdown.

<p>End of backup time</p>  <p>1 beep every 1 seconds</p>	<p>The UPS is on Battery mode and the battery is running low.</p>	<p>This warning is approximate, and the actual time to shutdown may vary significantly.</p>
<p>High Efficiency mode</p> 	<p>The UPS is operating on High Efficiency mode.</p>	<p>Once mains power is lost or abnormal, the UPS would transfer to Line mode or Battery mode and the load is supplied continuously.</p> <ol style="list-style-type: none"> <li>1. The function could be enabled through the LCD setting or the software (WinPower, etc.)</li> <li>2. It is important to note that the transfer time of UPS output from HE mode to battery mode is about 10ms. But it is still too long for some sensitive equipment</li> </ol>
<p>Bypass mode</p> 	<p>An overload or a fault has occurred, or a command has been received, and the UPS is in Bypass mode.</p>	<p>Equipment is powered but not protected by the UPS.</p>
<p>Converter mode</p> 	<p>The UPS is operating on converter mode.</p>	<p>In converter mode, the UPS would free run with fixed output frequency (50Hz or 60Hz). Once the mains is loss or abnormal, the UPS would transfer to battery mode and the load is supplied continuously.</p> <ol style="list-style-type: none"> <li>1. The function could be enabled through the LCD setting or the software (WinPower, etc.).</li> <li>2. The load should be derating to 60% in converter mode.</li> </ol>
<p>Warning</p> 	<p>There are warnings during the operation of UPS. Normally these problems don't prevent normal operation</p>	<p>The UPS continues working, but the problem should be identified and resolved immediately or it could prevent normal operation of the UPS.</p>

<p>Fault</p> 	<p>A Serious problem has been detected.</p>	<p>The UPS would directly cut off the output or transfer to bypass, and alarm.</p>
<p>Overload</p> 	<p>The load exceeds the capacity of the UPS</p>	<p>Excess load should be removed to decrease the load placed on the UPS</p>
<p>Battery test</p> 	<p>UPS is executing a battery test</p>	<p>The UPS is performing a Battery test. This is normal self-maintenance by the UPS and is part of normal operation</p>
<p>Battery fail</p> 	<p>The UPS has detected a fault or a battery is disconnected</p>	<p>The symbol of battery failure would be shown and UPS will alarm. The fault should be investigated by a qualified UPS technician</p>
<p>UPS Parallel</p> 	<p>Using two or three UPS for heavy load or redundancy</p>	<p>Two or three UPSs are operating in parallel</p>

## 5.3 Display functions

Use the two middle buttons (▲ and ▼) to scroll through the menu structure. Press the Enter ( ← ) button to select an option. Press the ESC button to cancel or return to the previous menu.

When starting the UPS, the display is in the default UPS status summary screen.

Main menu	Submenu	Display information or Menu function
UPS status		[status summary screen] / [Alarm] / [Battery charging/Volt/level/remain time] / [mode/ Para Num. /Running
Measurements		[Load] W VA/ [Output/Current] A % / [Output/Voltage] V Hz/ [Input/Voltage] V Hz / [Battery] V % / [DC bus] V V / [temperature] °C / [Battery remaining time] Min
Control	Single battery test	Starts a manual battery test for single UPS
	Parallel UPS battery	Starts a manual parallel battery test
	Single UPS turn off	Turns off one UPS in a parallel UPS system
	Reset fault status	Clears active fault
	Clear event log	Clears events
	Restore factory set	Returns all settings to original values
Settings		Sets parameters
Event log		Event list
Identification		[Product type/model] / [Part/Serial number] / [UPS firmware]

## 5.4 User settings

The following table displays the options that can be changed by the user.

Submenu	Available settings	Default settings
Password	Key the password	USER
language	[English] [Chinese]	English
User password	[Disabled] [Enabled]	[Disabled]
Audible alarm	[Enabled] [Disabled]	[Enabled]
Output voltage	[208V] [220V] [230V] [240V] Can be changed in Standby mode and Bypass mode	[230V]
Output frequency	[Autosensing] [50Hz] [60Hz]	[Autosensing]
Power strategy	[Normal] [High efficiency] [Converter]	[Normal]
Auto bypass	[Enabled] [Disabled]	[Enabled]
Auto restart	[Enabled] [Disabled] Authorize the product to restart automatically when mains supply is restored after a complete discharge	[Enabled]
Dry in	[Disabled] [SON] [SOFF] [Maintain bypass]	[Disabled]
Dry out	[Loaded power] [On battery mode] [Battery low] [Battery disconnected] [Bypass output] [UPS normal]	[Loaded power]
Start on battery	[Enabled] [Disabled]	[Enabled]
External Battery Modules	[0~20]	[1]
External Battery AH Setting	[0~300]	[120]
Battery remaining time	[Disabled] [Enabled]	[Enabled]
Charger current	[0~4] 0~4A for standard model [0~12] 0~12A for long backup model	[1.4A] for 6K, [2A] for 10K [4A] for 6KS/10KS
Site wiring fault alarm	[Disabled] [Enabled]	[Disabled]
LCD contrast	[-5 ~ +5]	[+0]

---

## 5.5 UPS startup and shutdown



*Please switch off the connected loads before turning on the UPS, and switch on connected devices one by one after the UPS is turned on. Switch off all connected loads before turning off the UPS.*

### **Starting the UPS with mains power present**



*Verify that the total equipment ratings do not exceed the UPS capacity to prevent an overload alarm.*

To start the UPS via mains power:

Check all the connection is correct.

Power on the UPS, the fans will start. After that, the LCD will show the default UPS status summary screen.

Hold the  button continuously for more than 1 second, the buzzer will beep 1s, UPS starts to turn on.

A few seconds later, the UPS turns to Line mode. If the utility power is abnormal, the UPS will transfer to Battery mode without output interruption to the UPS.

### **Starting the UPS on Battery only (cold Start)**



*Before using this feature, the UPS must have been powered by utility power with output enabled at least once to ensure the unit is adequately charged.*

*After connecting the UPS to the battery, should wait 10s before pressing the  button for pre-charging the auxiliary power supply.*

*Battery start can be disabled. See "Start on battery" setting in user settings.*

### **To start the UPS on battery:**

Ensure all the connection are correct.

Pressing  button continuously for more than 100ms, the UPS would be powered on. At this time the fan begins to rotate. Then LCD will show the default UPS status summary screen after UPS finishing initialization self-test.

Pressing  button continuously for more than 1 second, the buzzer will beep for 300ms, UPS starts to turn on.

A few seconds later the UPS will transfer to Battery mode. If the mains power comes back the UPS will transfer to Line mode without output interruption of the UPS.

---

## **UPS shutdown with mains power**

To shut down the UPS with mains power:

Pressing the  button continuously for more than 3 seconds and the buzzer will beep for 300ms. After that the UPS will transfer to bypass mode immediately. When completing the above action UPS output voltage is still present. In order to cut off the UPS output simply remove the mains power supply. A few seconds later the LCD display will shut down and no output power is available from the UPS output terminal.

## **UPS shutdown without mains power**



To shut down the UPS without mains power:

Power off the UPS by pressing the  button continuously for more than 3 seconds, the buzzer will beep for 300ms at which point the UPS output will stop. A few seconds later the LCD display will power off.

## **5.6 LCD operation**

Except the default UPS status summary screen, the user can get more detailed information about UPS current status, various measurements, previous event records, UPS identification as well as change settings to fit the users own requirements and optimize the function of UPS.

### **The main menu**

In the default UPS status summary screen, when pressing  or  for less than 3 seconds, the UPS will display detailed information about alarm, battery and system status.

In the default UPS status summary screen, when pressing ESC for more than 3 seconds, the display will enter main menu tree.

The main menu tree includes six branches:

- UPS status
- measurement
- event log
- control
- identification menu
- settings

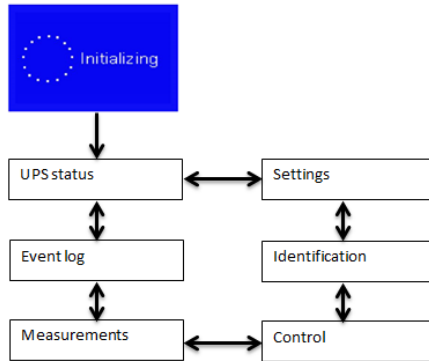

### The UPS status menu

By pressing **←** on the menu of “UPS status”, the display will enter the next UPS status menu tree.

The content of UPS status menu tree is the same as the default UPS status summary menu.

By pressing **ESC** for more than 3 seconds, the display will return to the last main menu tree.

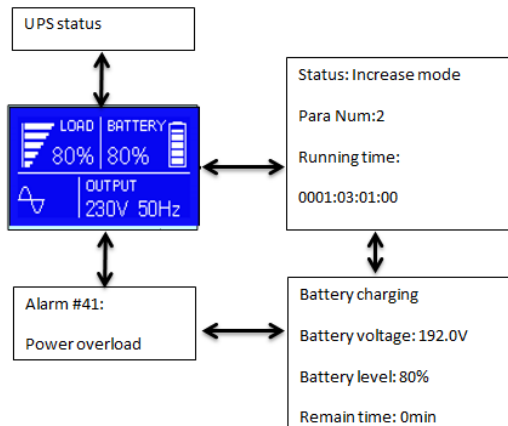

## The measurement menu

By pressing **↩** on the menu of “Measurement”, the display will enter the measurement menu tree.

A lot of detailed information can be checked here, including output voltage and frequency, output current, load capacity, input voltage and frequency, etc.

By pressing ESC for more than 3 Seconds the display will return to the last main menu tree.

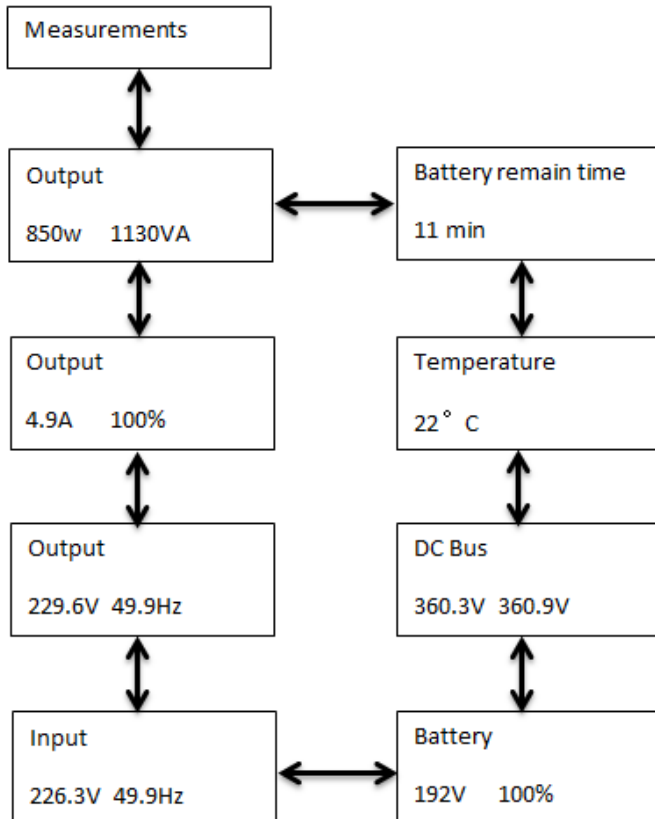

## The event log menu

By pressing **↩** on the menu of “Event log” the display will enter the next event menu tree.

All previous events, alarms and faults will have been recorded here. The information includes the description, event code, and the precise time when the event occurred. By press **▲** or **▼** for less than 3 seconds, all the events could be displayed one by one.

The maximum number of recorded events is 100, when the number is larger than 100, the oldest event will be overwritten.

By pressing **ESC** for more than 3 seconds the display will return to the last main menu tree.

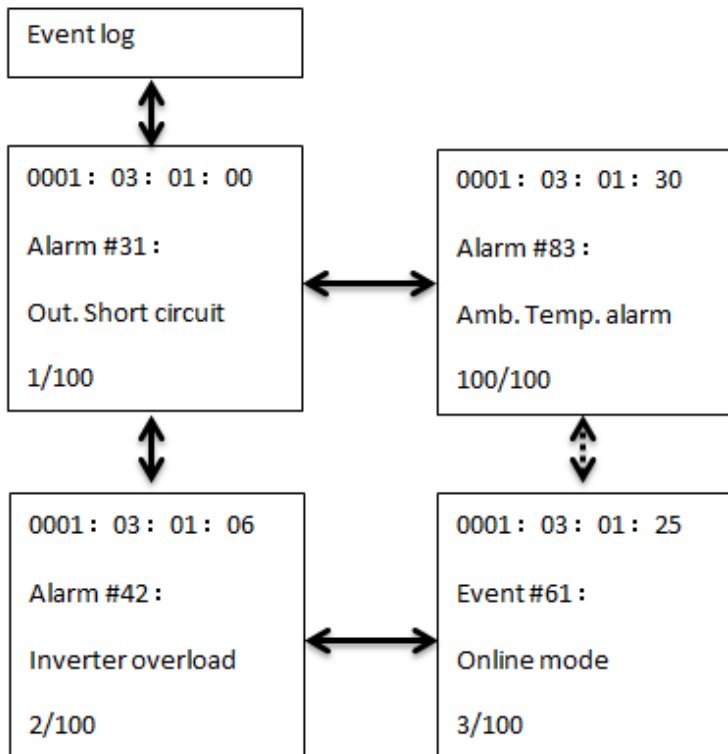



## The identification menu

By press **↵** on the menu of “Identification” the display enters the next identification menu tree.

The identification information includes UPS serial number, firmware version and model.

By press **ESC** for more than 3 seconds the display will return the last main menu tree.

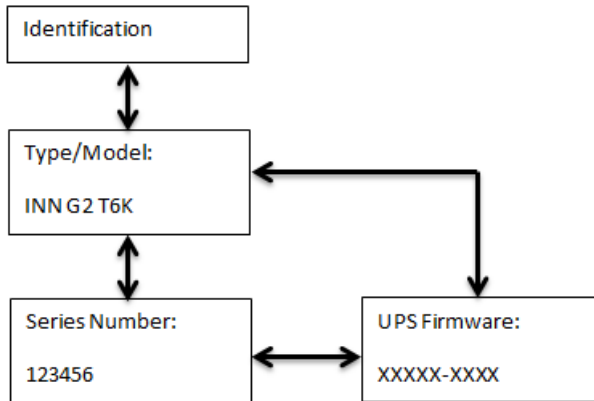

## The setting menu



Please contact your local distributor for further information before using the settings. Some settings would be changed the specification, and some settings would enable or disable some functions. The unsuitable option setting by user may result in potential failures or protecting function loss, even directly damage the load, battery or UPS.

AH setting could be set via RS232 or USB communication. Default AH setting is disable.

Most of settings could only be done while UPS is in Bypass mode.

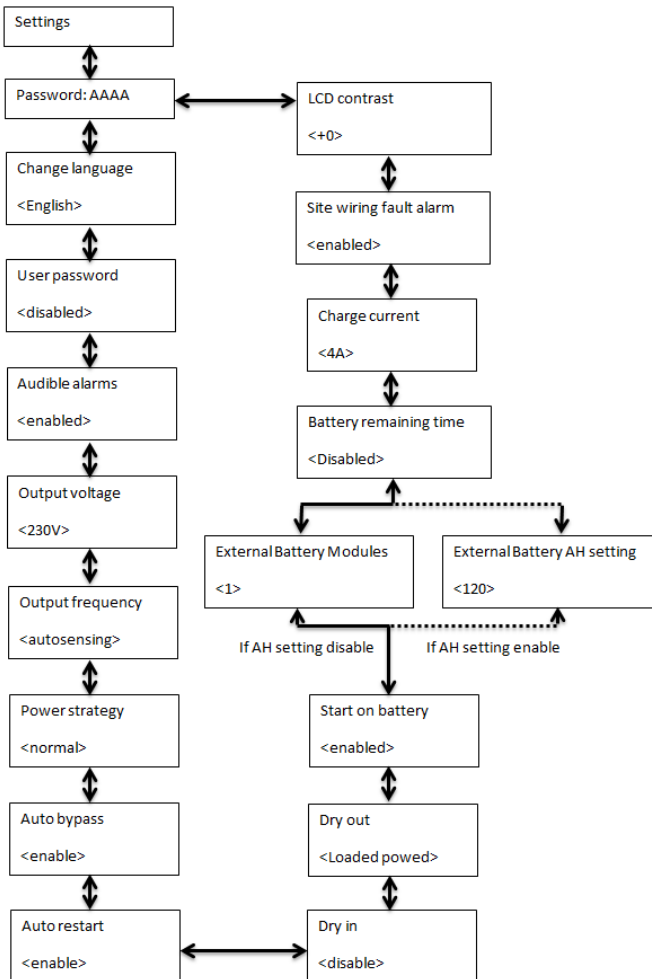

## Example: set rated output voltage value

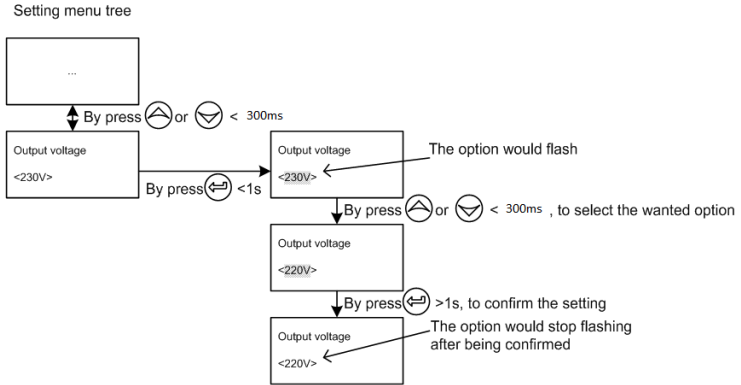

## 6. Communication

### 6.1 Communication ports

#### RS232 or USB communication ports



*The RS232 and USB communication ports cannot be used simultaneously.*

1. Connect the communication cable to the serial or USB port on the computer.
2. Connect the other end of the communication cable to the RS232 or USB communication port on the UPS.

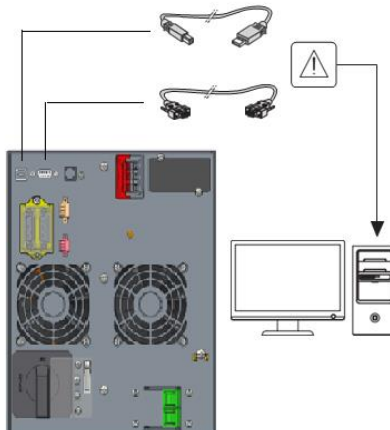

---

## Emergency Power off (EPO)

The Emergency Power Off interface provides an emergency power off function. When the EPO function is enabled (default setting the UPS will shut off the output and enter into EPO mode when the plug is removed. The UPS will also be unresponsive to all inputs until the EPO plug is reinserted into the UPS.

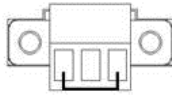

EPO

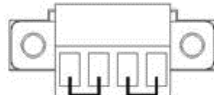

dry out      dry in

## Dry in & Dry out

Dry in allows maintenance bypass to be remotely switched on and off. When the contact changes the maintenance bypass is switched on or off depending on its current state.

## Dry out could indicate the status of UPS.

The Dry out port is normally closed, if the Dry out port is open it indicates an event has occurred such as;

- Output overload
- On battery mode
- Battery low
- Battery disconnected
- Bypass enabled

## 6.2 Network Management Card (Optional)

The Network Management Card allows the UPS to communicate with monitoring devices by utilizing network connectivity. The Online series has one available expansion bay for the following connectivity cards:

1. UPS-MS Web/SNMP Card – this interface card provides SNMP and HTTP capabilities as well as monitoring through a Web browser interface using RJ45 10/100Mbps over TCP/IP.
2. AS400 card for AS400 communication protocol. Please contact your local distributor for details.

## 6.3 UPS Management Software

WinPower is software for UPS monitoring and management which provides a user friendly interface as well as 2 way control of your UPS. This unique software provides automatic shutdown functionality for multi computer systems when power failure is detected. With this software users can monitor and control multiple UPSs on the same network no matter the distance.

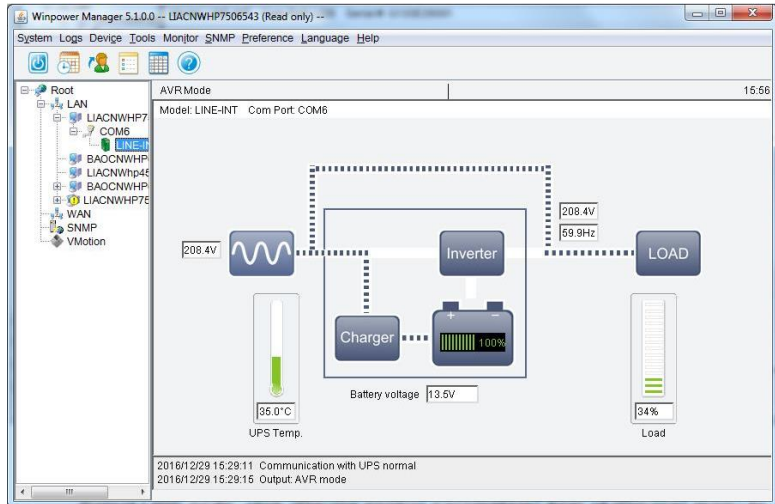

Installation procedure:

1. Go to the website:

<http://www.ups-software-download.com/>

2. Choose the operating system you need and follow the instruction described on the website to download the software.

3. When downloading all required files from the internet, enter the product key: **511C1-01220-0100-478DF2A** to install the software.

When the installation finishes restart your computer, the WinPower software will appear as a green plug icon located in the system tray, near the clock.

---

## 7. UPS maintenance

### 7.1 Equipment care

For the best preventive maintenance keep the area around the equipment clean and free from dust. If the atmosphere is very dusty, clean the outside of the system with a vacuum cleaner.

For maximum battery life keep the equipment at an ambient temperature of 25°C (77°F).



*The batteries are rated for a 3-5 year service life. The service life varies depending on the frequency of usage and ambient temperature. Batteries used beyond expected service life will often have severely reduced runtimes. Replace batteries at least every 4 years to keep units running at peak efficiency and prevent failure.*

### 7.2 Transporting the UPS



*The internal UPS batteries MUST be disconnected before transport.*



The following procedure should be performed or supervised by personnel knowledgeable about batteries and the required precautions. Keep unauthorized personnel away from batteries. If the UPS requires any type of transportation, the batteries must be disconnected (but not removed) before the unit is transported:

1. Verify that the UPS is off and disconnected from mains power.
2. Place the UPS on a flat stable surface with the front of the cabinet facing you.
3. Remove the UPS front cover
4. Disconnect the internal battery connectors
5. Replace the UPS front cover

### 7.3 Storing the equipment

If you store the equipment for a long period, recharge the battery every 6 months by connecting the UPS to utility power. The EBM charge to 90% capacity in less than 3 hours however it is recommended that the batteries charge for 48 hours after long-term storage. Check the battery recharge date on the shipping carton label if the date has passed and the batteries were never recharged do not use them.

## 7.4 Replacing batteries



*DO NOT DISCONNECT the batteries while the UPS is in Battery mode.*



Consider all warnings, cautions, and notes before replacing batteries.

- Servicing should be performed by qualified service personnel knowledgeable of batteries and required precautions. Keep unauthorized personnel away from batteries.
- Batteries can present a risk of electrical shock or burn from high short circuit current. Observe the following precautions:
  1. Remove watches, rings, or other metal objects,
  2. Use tools with insulated handles,
  3. Do not lay tools or metal parts on top of batteries,
  4. Wear rubber gloves and boots.
- When replacing batteries, replace with the same type and number of batteries or battery packs. Contact your service representative to order new batteries.
- Batteries must be disposed of responsibly. Refer to your local regulations for disposal requirements.
- Never dispose of batteries in a fire. Batteries may explode when exposed to flame.
- Do not open or modify the battery or batteries in any way. Released electrolyte is harmful to the skin and eyes and may be extremely toxic.
- Determine if the battery is inadvertently grounded. If inadvertently grounded, remove source from ground. Contact with any part of a grounded battery can result in electrical shock.
- The likelihood of shock can be reduced if grounds are removed during installation and maintenance (applicable to equipment and remote battery supplies not having a grounded supply circuit).
- **ELECTRIC ENERGY HAZARD.** Do not attempt to alter any battery wiring or connectors. Attempting to alter wiring can cause injury.
- Disconnect charging source prior to connecting or disconnecting battery terminals.

## Replacing the EBM (External battery module)



The EBM is heavy and requires a minimum of 2 people to lift in to racking.

For the Tower module, turn the MBS to bypass and switch off the input and then replace the EBM(s).

For the rotation module, if a PDU is connected to the UPS, turn the MBS to bypass and switch off the input, it is then safe to replace the EBM(s). If a PDU is not connected to the UPS, turn off the UPS and then replace the EBM.

### To replace the EBM(s):

1. Unplug the EBM power cable and battery detection cable from the UPS.  
If additional EBM(s) are installed, unplug the EBM power cable from each EBM.
2. Replace the EBM(s). See "Recycling the used equipment" for proper disposal.



*A small amount of arcing may occur when connecting an EBM to the UPS. This is normal and will not cause shock. Insert the EBM cable into the UPS battery connector quickly and firmly.*

3. Plug the EBM cable(s) into the battery connector(s).
4. Verify that the EBM connections are tight and that adequate bend radius and strain relief exist for each cable.
5. Connect the battery detection cable(s) to the connector of the UPS and of the EBM(s).

### To test new batteries:

1. Charge the batteries for 48 hours.
2. Press  on the menu of "Control".
3. Select Control
4. Select Single battery test

The UPS starts a battery test if

1. The batteries are fully charged
2. The UPS is in Normal mode with no active alarms
3. Bypass voltage is acceptable.

During the battery test, the UPS transfers to Battery mode and discharges the batteries for 10 seconds. The front panel displays  and the percentage of the test completed.

## 7.5 Recycling the used equipment

Contact your local recycling or hazardous waste center for information on proper disposal of the used equipment.



Do not dispose of the battery or batteries in a fire. Batteries may explode. Proper disposal of batteries is required. Refer to your regulations for disposal requirements.

Do not open or modify the battery or batteries. Released electrolyte is toxic and harmful to the skin and eyes.



Pb

Do not discard the UPS or the UPS batteries in the general waste. This product contains sealed lead acid batteries and must be disposed of responsibly. For more information contact your local recycling center.



Do not discard of waste electrical or electronic equipment (WEEE) in the trash. For proper disposal contact your local recycling center.

## 8. Troubleshooting

The C500® G2 is designed for durable, automatic operation and also to alert you whenever potential operating problems occur. Usually the alarms shown by the control panel do not mean that the output power is affected. Instead they are preventive alarms intended to alert the user.

- **Events** are silent status information that are recorded into the Event log. Example = "AC freq in range".
- **Alarms** are recorded into the Event log and displayed on the LCD status screen with the logo blinking. Some alarms may be announced by a beep every 1 second. Example = "Battery low".
- **Faults** are announced by a continuous beep and red LED recorded into the Event log. Example = Out. Short circuit.

Use the following troubleshooting chart to determine the UPS alarm condition.

## 8.1 Typical alarms and faults

To check the Event log:

1. By pressing  on the menu of “Event log”.
2. Scroll through the listed events or faults.
3. The following table describes typical conditions.

Conditions	Possible cause	Action
<b>Battery mode</b> Battery (Orange) LED is On. 1 beep every 4 seconds. Code: E062	A utility failure has occurred and the UPS is in Battery mode.	The UPS is powering the equipment with battery power. Prepare your equipment for shutdown.
<b>Battery low</b> Battery (Orange) LED is On. 1 beep every 1 second. Code: A012	The UPS is in Battery mode and the battery is running low.	This warning is approximate and the actual time to shutdown may vary significantly, this depends on the UPS load and number of Extended Battery Modules (EBMs).
<b>No battery</b> Fault (Red) LED is Flash 1 beep every 1 second Code: A011	The batteries are disconnected.	Verify that all batteries are properly connected. If the fault persists contact your service representative.
The UPS does not provide the expected backup time.	The batteries need charging or service is required.	Apply utility power for 48 hours to charge the batteries. If the condition persists contact your service representative.
<b>Bypass mode</b> Bypass (Orange) LED is on. Code: E060	An overload or a fault has occurred or a command has been received putting the UPS in Bypass mode	Equipment is powered but not protected by the UPS. Check for one of the following alarms: over temperature, overload or UPS failure.

<p><b>Power overload</b> Fault (Red) LED is Flash 2 beeps every 1 second Code: A041</p>	<p>Power requirements exceed the UPS capacity</p>	<p>Remove some of the equipment from the UPS. The UPS will continue to operate but may switch to Bypass mode or shut down if the load increases. The alarm resets when the output load is reduced.</p>
<p><b>UPS over temperature</b> Fault (Red) LED is On. Beep continuous. Code: F081</p>	<p>The UPS internal heat sink temperature is too high or a fan has failed. At warning level the UPS generates the alarm but remains normal or battery mode. If the temperature rises another 2°C the UPS transfers to Bypass mode or Standby mode.</p>	<p>Clear vents and remove any heat sources. Allow the UPS to cool and ensure the airflow around the UPS is not restricted then restart the UPS. If the condition continues to persist contact your service representative.</p>
<p><b>ON Maintenance Bypass</b> Bypass (Orange) LED is on. Code: A072</p>	<p>UPS was manually commanded to switch to bypass and will remain in bypass until commanded out of bypass</p>	<p>Check the maintain bypass switch status</p>
<p><b>In HE Mode</b> Line (green) LED is on. Code: E063</p>	<p>The UPS is on bypass while operating on the High efficiency setting.</p>	<p>The equipment transferred to bypass utility power as a normal function of High Efficiency operation. Battery mode is available and your equipment is protected.</p>
<p><b>Site Wiring Fault</b> Fault (Red) LED is flash 1 beep every 1 second Code: A004</p>	<p>Site Fault detection is supported on all models anytime there is a Grounded Neutral connection. Alarm triggers when the difference between ground and neutral voltage is &gt; 15v.</p>	<p>Site Fault detection should be enabled by default. It can still be enabled and disabled from the LCD settings menu. Reconnect all input wires.</p>

<p><b>Back feed</b>            Fault (Red) LED is On.            Beep continuous.            Code: F093</p>	<p>UPS has a unexpected bypass current on battery mode</p>	<p>Transfer to maintenance bypass and call service.</p>
<p><b>Inv Overload Fault</b>            Fault (Red) LED is On            Beep continuous.            Code: F042</p>	<p>UPS has transferred to bypass or fault mode because of overload in inverter mode</p>	<p>The UPS transfers to Battery mode if supporting the load.            Remove some of the output load from the UPS</p>
<p><b>Bypass Overload Fault</b>            Fault (Red) LED is On.            Beep continuous.            Code: F043</p>	<p>UPS has cut off the output and transferred to fault mode because of overload in bypass mode or HE mode.</p>	<p>Remove some of the output load from the UPS</p>
<p><b>Output Short Circuit</b>            Fault (Red) LED is On.            Beep continuous.            Code: F031</p>	<p>Indicates that the UPS has detected abnormally low impedance placed on its output and considers it a short circuit</p>	<p>Remove all output loads.            Turn off the UPS.            Check UPS output for possible short circuit.            Ensure short circuit is removed before turning on again.</p>
<p><b>Fan Failure</b>            Fault (Red) LED is flash            1 beep every 1 second            Code: A085</p>	<p>Indicates that the fan could not operate normally</p>	<p>Check fans of UPS</p>
<p><b>BUS Over Voltage</b>            Fault (Red) LED is On.            Beep continuous.            Code: F021</p>	<p>Indicates that the UPS is reporting a BUS over voltage fault.</p>	<p>The UPS transfers to Bypass mode if supporting the load</p>
<p><b>BUS Under Voltage</b>            Fault (Red) LED is On.            Beep continuous.            Code: F022</p>	<p>Indicates that the UPS is reporting a BUS under voltage fault.</p>	<p>The UPS transfers to Bypass mode if supporting the load</p>
<p><b>BUS Unbalance</b>            Fault (Red) LED is On.            Beep continuous.            Code: F023</p>	<p>Indicates that the positive BUS voltage and negative BUS voltage are out of tolerance.</p>	<p>The UPS transfers to Bypass mode if supporting the load</p>

<p><b>BUS Short</b> Fault (Red) LED is On. Beep continuous. Code: F024</p>	<p>Indicates that the BUS voltage decreased out of tolerance</p>	<p>Contact your service representative</p>
<p><b>BUS Softstart Fail</b> Fault (Red) LED is On. Beep continuous. Code: F025</p>	<p>Indicates that the BUS could not soft start successfully</p>	<p>Contact your service representative</p>
<p><b>Inv Over Voltage</b> Fault (Red) LED is On. Beep continuous. Code: F032</p>	<p>Indicates that the UPS reported an inverter over voltage fault</p>	<p>The UPS transfers to Bypass mode if supporting the load</p>
<p><b>Inv Under Voltage</b> Fault (Red) LED is On. Beep continuous. Code: F033</p>	<p>Indicates that the UPS get inverter under voltage fault</p>	<p>The UPS transfers to Bypass mode if supporting the load</p>
<p><b>Inverter Softstart Fail</b> Fault (Red) LED is On. Beep continuous. Code: F034</p>	<p>Indicates that the inverter could not soft start successfully</p>	<p>Contact your service representative</p>
<p><b>Charger Fail</b> Fault (Red) LED is flashing 1 beep every 1 second Code: A015</p>	<p>Indicates that the UPS has confirmed the charger has failed</p>	<p>The UPS turns off the charger until the next power cycle. Contact your service representative</p>
<p><b>Battery Over Voltage</b> Fault (Red) LED is On. Beep continuous. Code: F016</p>	<p>Indicates that the battery voltage is too high</p>	<p>The UPS will turn off the charger until the battery voltage is normal</p>
<p><b>Negative power Fault</b> Fault (Red) LED is On. Beep continuous. Code: F0E1</p>	<p>In parallel configurations a single UPS is reporting negative fault.</p>	<p>Redundancy mode, the faulty UPS triggers a fault, all UPSs in parallel configuration will generate a fault code. Contact your service representative</p>

<p><b>Parallel cable loss</b> Fault (Red) LED is On. Beep continuous. Code: F0E2</p>	<p>In parallel configurations a parallel cable disconnect</p>	<p>Reconnect the parallel cable to clear the fault. If issue persists contact your service representative</p>
<p><b>Parallel system battery status</b> Fault (Red) LED is flash 1 beep every 1 second Code: A0E6</p>	<p>In parallel configurations a UPS is reporting a fault with batteries/EBM.</p>	<p>Check battery connections</p>
<p><b>Line input different</b> Fault (Red) LED is flash 1 beep every 1 second Code: A0E7</p>	<p>Within parallel system, UPS1 inout ok, UPS2 input lost</p>	<p>Check the line input</p>
<p><b>Power strategy different</b> Fault (Red) LED is flash 1 beep every 1 second Code: A0E9</p>	<p>Parallel system, UPS mode not consistent through configuration i.e. normal, converter, HE are different</p>	<p>Check UPS OP mode, set OP mode be the same</p>
<p><b>Rated power difference</b> Fault (Red) LED is flash 1 beep every 1 second Code: A0EA</p>	<p>Power rating between individual ups in parallel are different</p>	<p>Ensure all power ratings within the parallel are the same</p>
<p><b>HE in parallel</b> Fault (Red) LED is flash 1 beep every 1 second Code: A0EB</p>	<p>Within parallel systems one or more UPS modes are set as HE</p>	<p>HE not allow in parallel configurations</p>

## 8.2 Silencing the alarm

Press the ESC (Escape) button on the front panel display for 2 Seconds to silence the alarm. Check the alarm condition and perform the applicable action to resolve the condition. If an alarm status changes the alarm will need to be silenced again.

## 9. Specifications

### 9.1 Model specifications

Table 1. Power Module model list

Model	Power Ratings
Tower standard 6K UPS	6000VA / 6000W
Tower standard 10K UPS	10000VA / 10000W
Tower long backup time 6KS UPS	6000VA / 6000W
Tower long backup time 10KS UPS	10000VA / 10000W
RT standard 6K UPS	6000VA / 6000W
RT standard 10K UPS	10000VA / 10000W
RT long backup time 6KS UPS	6000VA / 6000W
RT long backup time 10KS UPS	10000VA / 10000W

Table 2. Extended Battery Module model list

Model	Configuration	Battery voltage	For power ratings
Tower EBM	Tower	192Vdc	6000-10000VA
Tower EBM	Tower	240Vdc	6000-10000VA
RT EBM	RT	192Vdc	6000-10000VA
RT EBM	RT	240Vdc	6000-10000VA

**Table 3. Weights and dimensions**

Description	Weights (kg)	Dimensions (mm) W x H x D
Tower standard 6K UPS 16PCS BAT	52.7	220*589*492
Tower standard 6K UPS 20PCS BAT	61.9	220*589*492
Tower standard 10K UPS 16PCS BAT	60.3	220*589*492
Tower standard 10K UPS 20PCS BAT	70.3	220*589*492
Tower long backup time 6KS UPS	13	220*348*492
Tower long backup time 10KS UPS	15.2	220*348*492
Tower EBM 16*2 BAT	84.6	220*589*487
Tower EBM 20*2 BAT	102	220*589*487
RT standard 6K UPS	13	438* 86.2* 573
RT standard 10K UPS	14.7	438* 86.2* 573
RT long backup time 6KS UPS	13.1	438* 86.2* 573
RT long backup time 10KS UPS	15	438* 86.2* 573
RT EBM 16 BAT	45.4	438*129* 593
RT EBM 20 BAT	54.6	438*129* 593

**Table 4. Electrical input**

<b>Nominal frequency</b>	50/60Hz auto-sensing
<b>Frequency range</b>	40 Hz– 70 Hz≤60% rated load 45 Hz– 55 Hz(50Hz system)
	54 Hz – 66 Hz (60Hz system) >60% rated load
	45 Hz– 55 Hz 54 Hz – 66 Hz >60% rated load
<b>Bypass voltage range</b>	176~264Vac (default)
<b>Noise filtering</b>	MOV for normal and common mode noise

Model	Default input (Voltage/Current)	Selectable input Voltage range	Voltage at 100% Load
Tower/RT 6K 16PCS BAT	230V / 31.2A	208/220/230/240V	176~275Vac
Tower/RT 6K 20PCS BAT	230V / 32.3A	208/220/230/240V	176~275Vac
Tower/RT 6KS 16PCS BAT	230V / 38.7A	208/220/230/240V	176~275Vac
Tower/RT 6KS 20PCS BAT	230V / 42.3A	208/220/230/240V	176~275Vac
Tower/RT 10K 16PCS BAT	230V / 49.9A	208/220/230/240V	176~275Vac
Tower/RT 10K 20PCS BAT	230V / 50.9A	208/220/230/240V	176~275Vac
Tower/RT 10KS 16PCS BAT	230V / 57.6A	208/220/230/240V	176~275Vac
Tower/RT 10KS 20PCS BAT	230V / 60.2A	208/220/230/240V	176~275Vac

**Table 5. Electrical input connections**

Model	Input connection	Input cable
Tower 6K/6KS	Hardwired	Not provided
RT 6K/6KS		
Tower 10K/10KS		
RT 10K/10KS		

**Table 6. Electrical output**

All models	Normal mode	Battery mode
<b>Voltage regulation</b>	±1%	±1%
<b>Efficiency</b>	> 98% (High Efficiency mode) > 95%	> 93%
<b>Frequency regulation</b>	Sync with line ±10% of nominal line frequency (outside this range: ±0.1% of auto-selected nominal frequency)	±0.1% of auto-selected nominal frequency
<b>Nominal output</b>	208V*, 220V*, 230V, 240V, 250V* (voltage configurable) 6000/10000VA* 6000/10000W*	
<b>Frequency</b>	50 or 60Hz, autosensing or configurable as a frequency converter	
<b>Output overload</b>	100-105% : no alarm 105-125% : load transfers to Bypass mode after 10 minutes 125-150% : load transfers to Bypass mode after 30s	
<b>Output overload (Bypass mode)</b>	100-105% : no alarm 105-125% : continue working and alarm 125-150% : UPS shuts down after 30 seconds	
<b>Voltage waveform</b>	Sinewave	
<b>Harmonic distortion</b>	< 1% THDV on linear load < 5% THDV on non-linear load	

<b>Transfer time</b>	Online mode: 0 ms (no break) High Efficiency mode: 10ms maximum (due to loss of utility)
<b>Power factor</b>	1
<b>Load crest ratio</b>	3 to 1

\* 200/208/250V are derated at 10000VA 9000W, 220V is derated at 9900W for 11kVA models.

Table 7. Electrical output connections

Model	Output connection	Output cable
Tower 6K/6KS	Hardwired	Not provided
RT 6K/6KS		
Tower 10K/10KS		
RT 10K/10KS		

Table 8. Environmental and safety

<b>EMC certifications</b>	IEC/EN 62040-1 IEC/EN 62040-2 IEC/EN 62040-3 IEC 60950-1
<b>EMC (Emissions)*</b>	IEC 61000-3-2 (-3-12) IEC 61000-3-3 (-3-11)
<b>EMC (Immunity)</b>	IEC 61000-2-2 IEC 61000-4-2, Level 4 IEC 61000-4-3, Level 3 IEC 61000-4-4, Level 4 (also on signal ports) IEC 61000-4-5, Level 4, Criteria B IEC 61000-4-6, Level 3 IEC 61000-4-8, Level 4 IEC 61000-4-11

\* For output cable < 10m.

<b>Agency markings</b>	CE
<b>Operating temperature</b>	0~40°C full load no derating 40~50°C output power derating to 50% load, Charger current derating 50%
<b>Storage temperature</b>	-15 to 40°C (32 to 104°F) with batteries -25 to 60°C (5 to 140°F) without batteries
<b>Transit temperature</b>	-25 to 55°C (-13 to 130°F)

<b>Relative humidity</b>	0 to 95% no condensing
<b>Operating altitude</b>	Up to 3,000 meters (9,843 ft) above sea level with 10% derating per 1000m
<b>Transit altitude</b>	Up to 10,000 meters (32,808 ft) above sea level
<b>Audible noise</b>	< 50 dBA at 1 meter typical for 6kVA models < 55 dBA at 1 meter typical for 10kVA models

Table 9. Battery

	<b>EBMs</b>
<b>Rack / Tower configuration</b>	240Vdc 20 x 12V, 7Ah 240Vdc 20 x 12V, 9Ah 192Vdc 16 x 12V, 7Ah 192Vdc 16 x 12V, 9Ah
<b>Fuses</b>	100A for 10kVA models and EBM
<b>Type</b>	Sealed, maintenance-free, valve-regulated, lead-acid, with minimum 3-year float service life at 25°C (77°F). Lifetime is reduced above 30 °C.
<b>Monitoring</b>	Advanced monitoring for earlier failure detection and warnings.
<b>Battery port</b>	External ANEN-SA30 connector on power module for connection to EBM
<b>EBM battery cable length</b>	100cm for tower models 50cm for RT models

Table 10. Communication options

<b>Communication bay</b>	Available independent communication bay for connectivity cards
<b>Compatible connectivity cards</b>	MODBUS card NMC card AS400 card
<b>Communication ports</b>	RS-232 (DB9): 2400 bps USB: 2400 bps
<b>Dry out</b>	2 pins jumper (normally closed)
<b>Dry in</b>	2 pins jumper (normally closed)
<b>Emergency Power Off</b>	3 pins jumper (normally closed)

---

## 10 Glossary

Bypass AC source	Source supplying the bypass line. The equipment can be transferred to the bypass line if an overload occurs on the UPS output, for maintenance or in the event of a malfunction.
Frequency converter	Operating mode used to convert the AC-power frequency between the UPS input and output (50Hz -> 60Hz or 60Hz -> 50Hz).
Low-battery warning	This is a battery-voltage level indicating that battery power is low and that the user must take action to prevent the imminent loss to the supply of power to the output load.
Backup time	Time during which the load can be supplied by the UPS operating on battery power.
Load	Devices or equipment connected to the UPS output.
HE mode	Operating mode in which the load is supplied directly by the AC source if it is within the tolerances defined by the user. This mode reduces the consumption of electrical power
Manual bypass	Rotary switch controlled by the user used to connect the loads directly to the AC source. Transfer of the load to the manual bypass enables UPS maintenance without interrupting the supply of power to the connected loads.
Normal (double conversion) mode	The normal UPS operating mode in which the AC source supplies the UPS which in turn supplies the connected loads (after electronic double conversion).
Normal AC source	Normal source of power for the UPS.
Relay contacts	Contacts supplying information to the user in the form of signals.
UPS	Uninterruptible Power Supply.