

C800

10 - 30kVA Online Double Conversion

Suggested applications: Server rooms and small data centre environments

The C800 delivers superior performance, reliability and efficiency.

Featuring IGBT technology and intelligent DSP based control, the C800 solutions achieve unity power factor and industry leading efficiency of up to 97%.

With a considerably smaller footprint than other comparable three phase UPS solutions on the market, the C800 range also comes with parallel redundancy for superior resilience and extended optional runtime.

Key Features

- Dual input
- Wide input voltage window
- Parallel capability of up to 10 UPS in parallel
- Small footprint
- High efficiency on battery mode
- Transformer free design

TECHNOLOGY: C800, 30KVA **APPLICATION:** CAR PARTS MANUFACTURER

OBJECTIVE: PROVIDE POWER BACK UP TO INDUSTRIAL PRODUCTION LINE

"A large midlands based industrial complex relied heavily on an efficient and constant production line. Even power was vital to ensure accurate machine calibration as well as avoiding line closures due to power loss. The C800 provided critical three phase power back up as well as providing FM management had constant reassurance of production capability."



ECO mode function



USB connectivity



Pure sinewave output



Intelligent communication slot



High efficiency



Additional battery connection



Parallel connection



Dual input



Online double conversion



Three phase



Maintenance bypass switch



MODELS	C800-10	C800-15	C800-20	C800-30
Power (VA) max	1000	1500	2000	3000
Power (W) max	1000	1500	2000	2700
INPUT				
Voltage	380/400/415VAC			
Voltage Tolerance	280-500VAC			
Frequency	50/60Hz			
Frequency Tolerance	±10%			
Phase	Three			
OUTPUT				
Power Factor	1		0.9	
Waveform	Pure Sinewave			
Voltage	380/400/415VAC			
Frequency	50/60Hz			
Efficiency	95% Online Mode			
Phase	Three			
BATTERY				
Runtime	N/A			
DC Voltage	480VAC			
Charger Capacity	3.3A	5A	6.6A	10A
MECHANICAL				
Weight	52kg		89kg	
Dimensions (WxDxH)	250 x 865 x 715mm		350 x 760 x 1335mm	
AC Outlets	Terminal Block			
ENVIRONMENTAL				
Operating Temperature Tolerance	UPS: 0°C - 40°C, Batteries: 20 - 25°C			
Storage Temperature Tolerance	UPS: -10°C - 50°C			
Relative Humidity	0-95% Relative Humidity (Non Condensing)			
Operating Altitude Tolerance	>1000m			
FEATURES				
Communication	USB, RS232, RS485 & Relay Connectivity			
Optional Comms	SNMP			
Functions	EPO, USB, Expandable Battery Modules, LCD Display, Dual Input			

Full technical specification and product information can be found at www.certaups.com



CertaUPS

Mode	C800-10	C800-15	C800-20	C800-30
Main Input				
Phase Input	3 Phases + Neutral + Ground			
Input Voltage	380/400/415VAC (Line-Line)			
Frequency	50/60Hz			
Input Voltage Range	304~478Vac (Line-Line),full load; 228V~304Vac (Line-Line),load decreases linearly according to the min phase			
Input Frequency Range	40Hz ~ 70Hz			
Input Power Factor	>0.99			
Input Current THDi	<4% (full Linear Load)		<3% (full Linear Load)	
Bypass Input				
Bypass Voltage	380/400/415VAC (Line-Line)			
Frequency	50/60Hz			
Bypass Voltage Range	Selectable, default -20% ~ +15%; Upper limit: +10%, +15%, +20%, +25%; Lower limit: -10%, -15%, -20%, -30%, -40%			
Bypass Frequency Range	Selectable, ±1Hz, ±3Hz, ±5Hz			
Bypass Overload	125% Long term operation; 125%~130% for 10min; 130%~150% for 1min;			
Output				
Rated Inverter Voltage	380/400/415VAC (Line-Line)			
Rated Frequency	50/60Hz			
Output Power Factor	1		0.9	
Voltage precision	±1.5%(0-100% linear load)			
Transient Response	<5% for step load (20% - 80% -20%)			
Transient recovery	< 30ms for step load (20% - 100% -20%)			
Output Voltage THDu	<1% (linear load); <5.5% (non-linear load) according to IEC/EN62040-3		<1% linear load; <6 (non-linear load) according to IEC/EN62040-3	
Inverter Overload	<110%, 60min; 110%~125%,10min; 125%~150%,1min;			
Frequency Regulation	50/60Hz±0.1%			
Synchronized Range	Settable, ±0.5Hz ~ ±5Hz, default ±3Hz			
Synchronized Slew Rate	Settable, 0.5Hz/S ~ 3Hz/s, default 0.5Hz/s			
Battery And Charger				
Battery Rate Voltage	±240VDC			
Charger Voltage precision	1%			
Charger Power	max=20% System Power			
Efficiency				
Normal Operation	95%max		>95%	
Battery Operation	94.5%max		>95%	

System				
Display	LED + LCD			
Interface	Standard: RS232, RS485 Option: SNMP, Dry Contact, Parallel kit, Battery cold start			
Environmental				
Operation Temperature	0 ~ 40 °C			
Storage Temperature	-40 ~ 70 °C			
Relative Humidity	0 ~ 95% (Non condensing)			
Noise (1 meter)	58dB @ 100% load, 52dB @ 45% load		65dB @ 100% load, 62dB @ 45% load	
Physical data				
Dimension (W*D*H,mm)	250*840*715	250*840*715	350*738*1335	350*738*1335
Weigh(Kg)	51.5 (without battery)	51.5 (without battery)	89 (without battery)	89 (without battery)

C800 10-40kVA















Tower 10-40kVA

Installation/Manual

CertaUPS

Service and support
WWW.CERTAUPS.COM
INFO@CERTAUPS.COM
T: +44 (0)1246 431 431

-  Smart app monitoring
-  Dual input
-  Parallel connection
-  High efficiency up to 97%
-  Intelligent communications bypass switch
-  Maintenance
-  Online double conversion
-  USB connectivity & HID support
-  Additional battery connection
-  Eco-mode function
-  Virtualisation compatible
-  Pure sine wave output
-  Virtualisation compatible

Preface

Usage

The manual contains information on installing, using, operation and maintenance of the CertaUPS C800 UPS. Please carefully read this manual prior to installation.

Users

Technical Support Engineer
Maintenance Engineer

Note

Our company offer a full range of technical support and services. Customers can contact our local office or customer service center for help. The manual will update irregularly, due to the product upgrading or other reasons.

Unless otherwise agreed, the manual is only used as guide for users and any statements or information contained in this manual, expressed or implied, constitutes warranty.

Contents

1. Safety Precautions.....	5
Safety Message Definition.....	5
Warning Label	5
Safety Instruction	5
Move & Install	6
Debug & Operate	6
Maintenance & Replacement.....	6
Battery Safety.....	7
Disposal	7
2. Product Introduction.....	8
2.1 System Configuration	8
2.3 Operation Mode.....	8
2.3.1 Normal Mode	8
2.3.2 Battery Mode	9
2.3.3 Bypass Mode	9
2.3.4 Maintenance Mode (Manual Bypass)	10
2.3.5 ECO Mode	10
2.3.6 Auto-restart Mode	11
2.3.7 Frequency Converter Mode	11
2.4 UPS Structure	11
2.4.1 UPS Configuration	11
2.4.2 UPS Outlook	12
3. Installation Instruction	16
3.1 Location.....	16
3.1.1 Installation Environment.....	16
3.1.2 Site Selection.....	16
3.1.3 Size and Weight.....	16
3.2 Unloading and Unpacking	20
3.2.1 Moving and Unpacking of the Cabinet.....	20
3.3 Positioning.....	23
3.3.1 Positioning Cabinet	23
3.4 Battery.....	24
3.5 Cable Entry	24
3.6.1 Specifications	25
3.6.2 Specifications for Power Cables Terminal.....	26
3.6.3 Circuit Breaker	26
3.6.4 Connecting Power Cables.....	27
3.7 Control and Communication Cables.....	28
3.7.1 Dry Contact Interface	29
3.7.2 Communication Interface.....	34
4. LCD Panel.....	34
4.1 Introduction	34
4.2 LCD panel for Cabinet.....	34
4.2.1 LED Indicator	35

4.2.2 Control and Operation Keys	36
4.2.3 LCD Screen.....	37
4.3 System Information Window.....	39
4.4 Menu Window.....	39
4.5 Event List	40
5. Operations.....	43
5.1 UPS Start-up	43
5.1.1 Start from Normal Mode.....	43
5.1.2 Start from Battery	44
5.2 Procedure for Switching between Operation Modes.....	45
5.2.1 Switching the UPS into Battery Mode from Normal Mode	45
5.2.2 Switching the UPS into Bypass Mode from Normal Mode.....	45
5.2.3 Switching the UPS into Normal Mode from Bypass Mode.....	45
5.2.4 Switching the UPS into Maintenance Bypass Mode from Normal Mode	46
5.2.5 Switching the UPS into Normal Mode from Maintenance Bypass Mode	47
5.3 Battery Maintenance.....	47
5.4 EPO	48
5.5 Installation of Parallel Operation System	48
5.5.1 Parallel system diagram.....	48
5.5.2 Parallel system setting.....	50
6. Maintenance	53
6.1 Precautions.....	53
6.2 Instruction for Maintaining UPS.....	53
6.3 Instruction for Maintaining Battery string.....	53
6.2.4 Installation of internal battery	54
7. Product Specification	60
7.1 Applicable Standards.....	60
7.2 Environmental Characteristics.....	60
7.4 Electrical Characteristics	61
7.4.1 Electrical Characteristics (Input Rectifier)	61
7.4.2 Electrical Characteristics (Intermediate DC Link)	61
7.4.3 Electrical Characteristics (Inverter Output)	62
7.4.4 Electrical Characteristics (Bypass Mains Input).....	62
7.5 Efficiency	63
7.6 Display and Interface.....	63

1. Safety Precautions



This manual contains information concerning the installation and operation of the C800 series UPS. Please carefully read this manual prior to installation. The C800 UPS cannot be put into operation until it is commissioned by engineers approved by the manufacturer (or its agent). Not doing so could result in personnel safety risk, equipment malfunction and invalidation of warranty.

Safety Message Definition





- **Danger:** Serious injury or even death may be caused, if this requirement is ignored.
- **Warning:** Injury or equipment damage may be caused, if this requirement is ignored.
- **Attention:** Equipment damage, loss of data or poor performance may be caused if this requirement is ignored.
- **Commissioning Engineer:** The engineer who installs or operates the equipment should be electrically certified as well as being familiar with UPS systems.

Warning Label



The warning label indicates the possibility of injury or equipment damage, and advises the correct steps to avoid the danger. In this manual, there are three types of warning labels as below.

Labels	Description
 Danger	Serious injury or even death may be caused, if this requirement is ignored.
 Warning	Injury or equipment damage may be caused, if this requirement is ignored.
 Attention	Equipment damage, loss of data or poor performance may be caused, if this requirement is ignored.



Safety Instruction

 Danger	Performed only by qualified engineers. This UPS is designed for commercial and industrial applications. Where the ups is used for medical or life critical applications, It should only be done so in accordance with legal regulations and best practices.
 Warning	Read all the warning labels carefully before operation, and follow the instructions.
	When the system is running, do not touch the surface with this label, to avoid any hurt of scald.
	Electrostatic discharge sensitive components inside the UPS, anti-ESD measure should be taken before handling.

Move & Install

 Danger	<ul style="list-style-type: none"> • Keep the equipment away from heat source or air outlets. • In case of fire, use dry powder extinguisher only, any liquid extinguisher can result in electric shock.
 Warning	<ul style="list-style-type: none"> • Do not start the system if damaged. • Operating the UPS with wet hands or clothes may result in electric shock.
 Attention	<ul style="list-style-type: none"> • Use the correct equipment to handle and install the UPS. Safety shoes, protective clothes and other protective facilities are necessary to avoid injury. • During positioning, keep the UPS away from impact or vibration. • Install the UPS into a correct environment, more detail in section 3.3.

Debug & Operate

 Danger	<ul style="list-style-type: none"> • Make sure the grounding cable is well connected before connecting the power cables, the grounding cable and neutral cable must be in accordance with the local and national safety regulations. • Before moving or re-connecting the cables, make sure to cut off all the input power sources, and wait for at least 10 minutes for internal discharge. Use a multi-meter to measure the voltage on terminals and ensure the voltage is lower than 36V before operation.
 Attention	<ul style="list-style-type: none"> • The earth leakage current of load will be carried by RCCB or RCD. • Initial check and inspection should be performed after the UPS has been stored for long periods of time.

Maintenance & Replacement

 Danger	<ul style="list-style-type: none"> • All the equipment maintenance and servicing procedures involving internal access need special tools and should be carried out only by trained personnel. The components that can only be accessed by opening the protective cover with tools cannot be maintained by user. • This UPS full complies with “IEC62040-1-1-General and safety requirements for use in operator access area UPS”. Dangerous voltages are present within the battery box. However, the risk of contact with these high voltages is minimized for non-service personnel. Since the component with dangerous voltage can only be touched by opening the protective cover. No risk exists to any personnel when operating the equipment in the normal manner, following the recommended operating procedures in this manual.
--	--

Battery Safety

 Danger	<p>All battery maintenance and servicing procedures involving internal access need special tools or keys and should be carried out only by trained personnel. WHEN CONNECTED TOGETHER, THE BATTERY TERMINAL VOLTAGE WILL EXCEED 400VDC, THIS IS POTENTIALLY LEATHAL.</p> <p>Battery manufacturers supply details of the necessary precautions to be observed when working on, or in the vicinity of a large bank of battery cells. These precautions should be followed implicitly at all times. Particular attention should be paid to the recommendations concerning local environmental conditions and the provision of protective clothing, first aid and fire-fighting facilities.</p> <p>Ambient temperature is a major factor in determining the battery capacity and life. The nominal operating temperature of battery is 20°C-25°C. Operating above this temperature will reduce the battery life. Periodically charge the battery according to the battery user manuals to ensure the back-up time of UPS.</p> <p>Replace the batteries only with the same type and the same number or it may cause an explosion or poor battery performance.</p> <p>When connecting batteries follow the precautions for high-voltage operation before accepting and using the battery. Carry out a visual check, if the battery is damaged, the terminals dirty, corroded, rusted, the casing deformed or has leaked, replace it with new product. Otherwise battery capacity reduction, electric leakage or fire may occur.</p> <ul style="list-style-type: none">● Before operating the battery, remove rings, watches, necklaces, bracelets or any other metal jewelry● Wear rubber gloves.● Eye protection should be worn to prevent injury from electrical arcs.● Only use tools (e.g. wrench) with insulated handles.● The batteries are very heavy. Please handle and lift the battery in the correct manner to prevent any injury or damage to the battery terminal.● Do not modify or damage the batteries. Otherwise, battery short circuit, leakage or even injury may occur.● The battery contains sulfuric acid. In normal operation, all the sulfuric acid is attached to the separation board and plate in the battery. However, when the battery case is broken, the acid will leak from the battery. Therefore, be sure to wear a pair of protective glasses and rubber gloves when handling the battery.● At the end of the batteries life, the battery may develop an internal short circuit. If this occurs the battery may overheat, swell or leak. Be sure to replace the battery before this occurs.● If a battery leaks electrolyte or is otherwise physically damaged, it must be replaced, stored in a container resistant to sulfuric acid and disposed of in accordance with local regulations.● If electrolyte comes into contact with skin, the affected area should be washed immediately with water.
--	--

Disposal

 Warning	<ul style="list-style-type: none">● Dispose of used batteries according to the local instructions
--	---

2. Product Introduction

2.1 System Configuration

The Tower UPS is configured by the following parts: Rectifier, Charger, Inverter, Static Switch and Manual Bypass Switch. One or several battery strings should be installed to provide backup energy once the utility fails. The UPS structure is shown in Fig. 2-1.

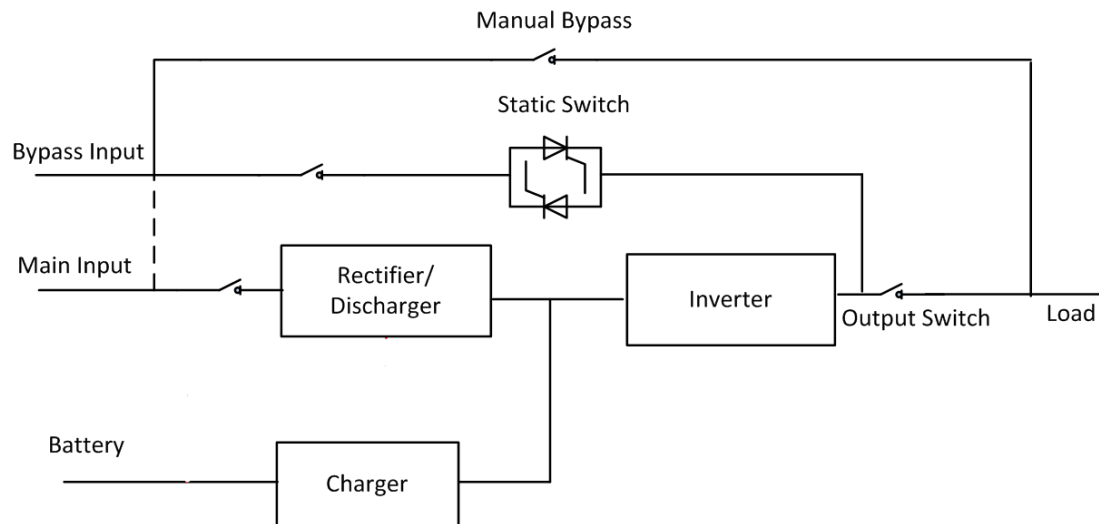

Fig. 2-1 UPS Configuration

2.3 Operation Mode

The C800 UPS is an Online, double-conversion UPS that permits operation in the following modes:

- Normal mode
- Battery mode
- Bypass mode
- Maintenance mode (manual bypass)
- ECO mode
- Auto-restart mode
- Frequency Converter mode

2.3.1 Normal Mode

The inverter continuously supplies the critical AC load. The rectifier/charger derives power from the AC mains input and supplies DC power to the inverter while simultaneously FLOAT or BOOST charging the backup battery.

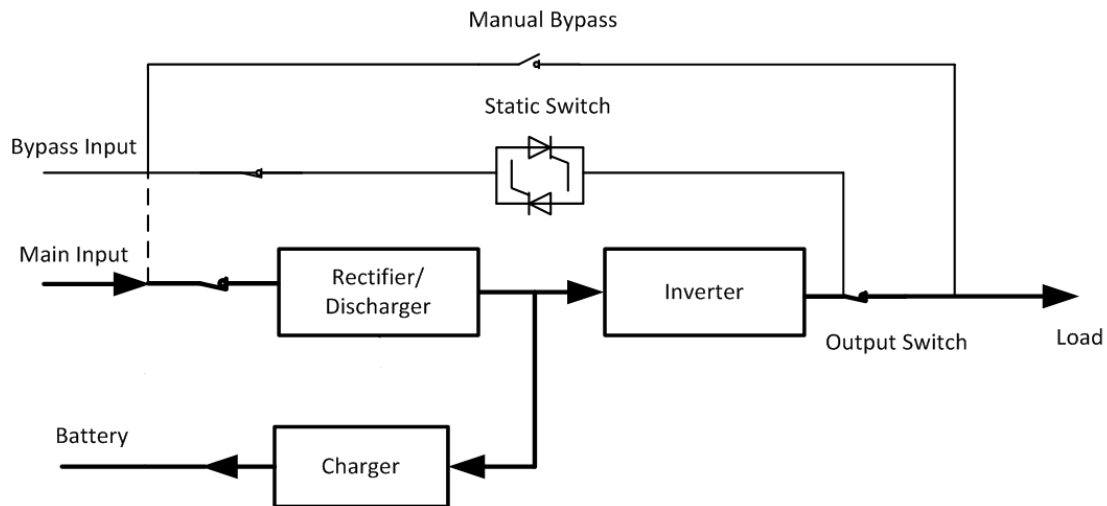

Fig 2-2 Normal mode operation diagram

2.3.2 Battery Mode

Upon failure of the AC mains power the inverter obtains power from the battery to supply the load. There is no interruption in power to the load upon failure. After restoration of the AC mains input power, "Normal mode" operation will resume automatically without user intervention.

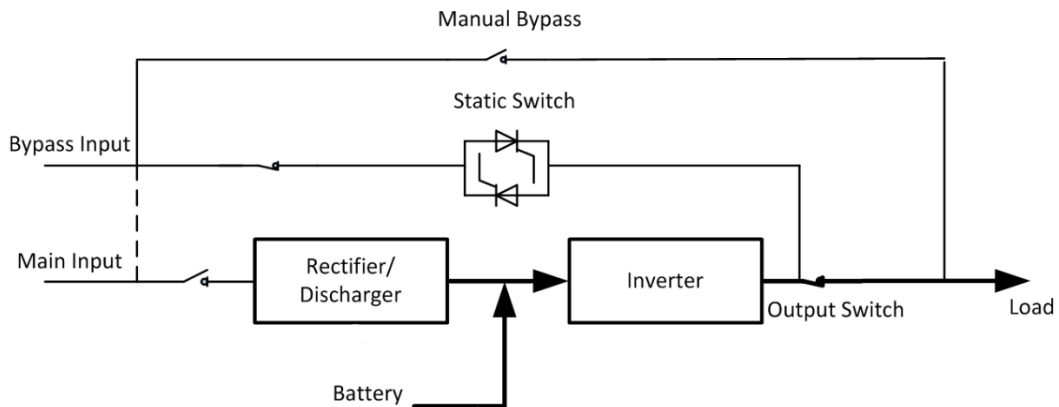

Fig 2-3 Battery mode operation diagram

Note

With the function "Battery cold start", the UPS may start without mains power. See more detail in section 5.1.2.

2.3.3 Bypass Mode

If the inverter overload capacity is exceeded under Normal mode, or if the inverter becomes unavailable for any reason the static transfer switch will perform a transfer of the load from the inverter to the bypass source with no interruption in power to the critical AC load. Should the inverter be asynchronous with the bypass the static switch will perform a transfer of the load from the inverter to the bypass with power interruption to the load. This is to avoid large cross currents due to the paralleling of unsynchronised AC sources. This interruption is programmable but typically set to be less than 3/4 of an electrical cycle, e.g., less than 15ms (50Hz) or less than 12.5ms (60Hz). The action of transfer/re-transfer can also be done by the command.

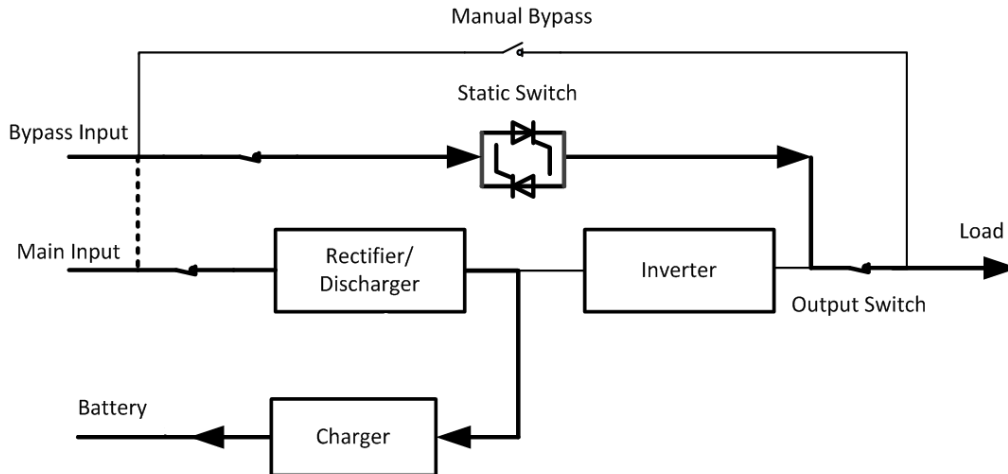

Fig. 2-4 Bypass mode operation diagram

2.3.4 Maintenance Mode (Manual Bypass)

A manual bypass switch is available to ensure continuity of supply to the critical load when the UPS becomes unavailable e.g. during a maintenance procedure. (See Fig.2-5).

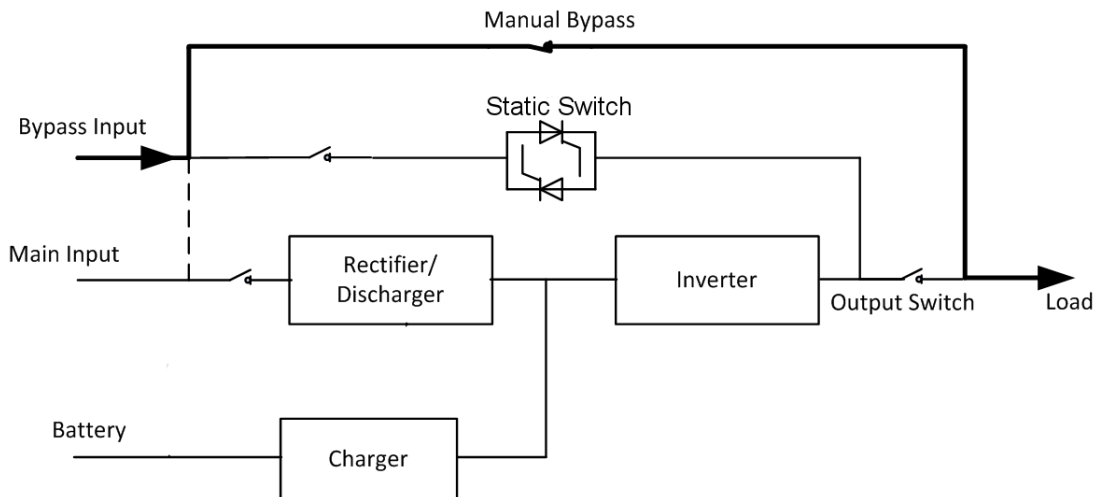

Fig. 2-5 Maintenance mode operation diagram



Danger

During Maintenance mode, dangerous voltages are present on the terminal of input, output and neutral, even with all the modules and the LCD turned off.

2.3.5 ECO Mode

To improve system efficiency, C800 UPS works in Bypass mode at normal time, and the inverter is on standby. When the utility fails, the UPS transfers to Battery mode and the inverter powers the loads.

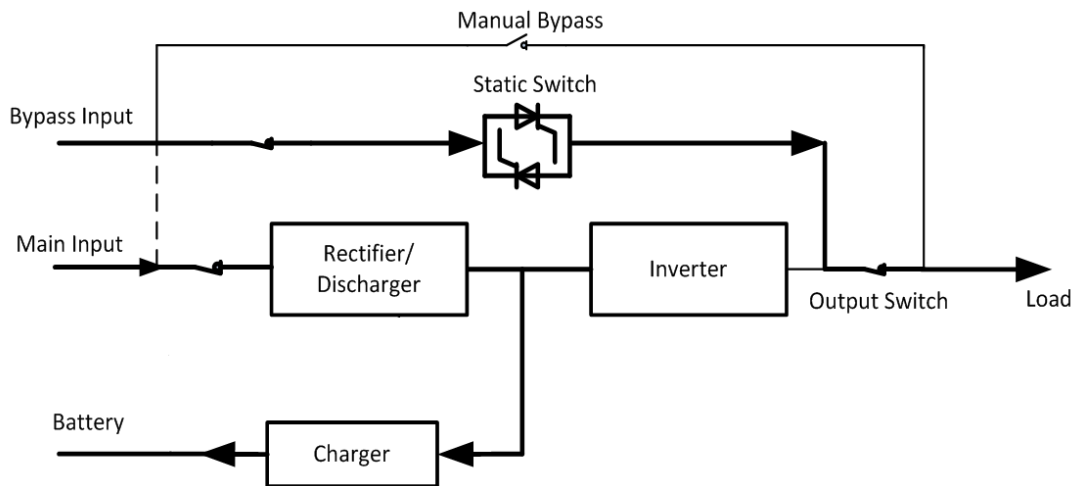

Fig.2-6 ECO Mode operation diagram

Note

There is a short interruption time (less than 10ms) when transferring from ECO mode to battery mode, it must be sure that the interruption has no effect on the critical load.

2.3.6 Auto-restart Mode

The battery may become exhausted following an extended AC mains failure. The inverter shuts down when the battery reaches the End of Discharge Voltage (EOD). The UPS may be programmed to “System Auto Start Mode after EOD”. The system starts after a delay time when the AC mains recovers. The mode and the delay time are programmed by the commissioning engineer.

2.3.7 Frequency Converter Mode

By setting the UPS to Frequency Converter mode, the UPS could present a stable output of fixed frequency (50 or 60Hz), however the bypass static switch is not available.

2.4 UPS Structure

2.4.1 UPS Configuration

The UPS configuration is provided in Table 2.1

Table2.1 UPS Configuration

Item	Components	Quantity	Remark
Standard Backup Type	Circuit Breakers	5	Standard
	Dual Input	1	Standard
	Parallel Card	1	Optional
	Dry Contact Card	1	Optional
Long Backup Type	Circuit Breakers	4	Standard
	Dual Input	1	Standard
	Parallel Card	1	Optional
	Dry Contact Card	1	Optional

2.4.2 UPS Outlook

The UPS outlook is shown as Fig.2-7 to Fig. 2-13.

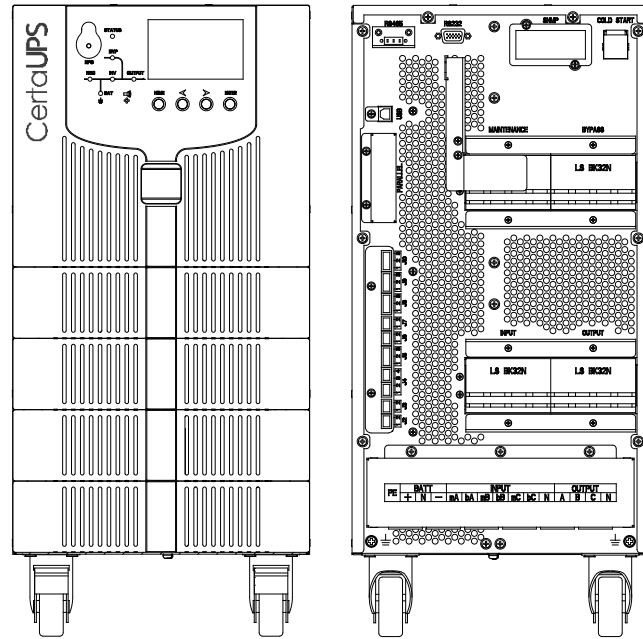

Fig.2-7 10/15kVA System outlook (Long backup type)

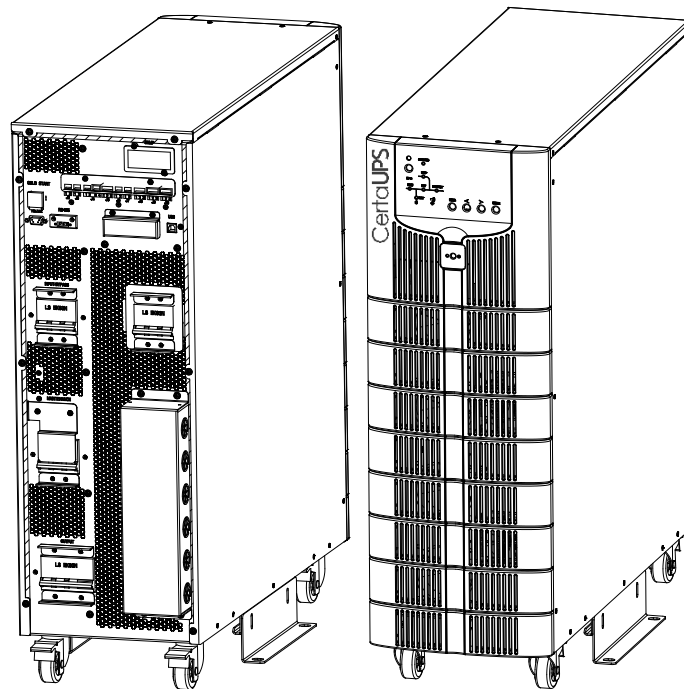

Fig.2-8 20/30kVA System outlook (Long backup type)

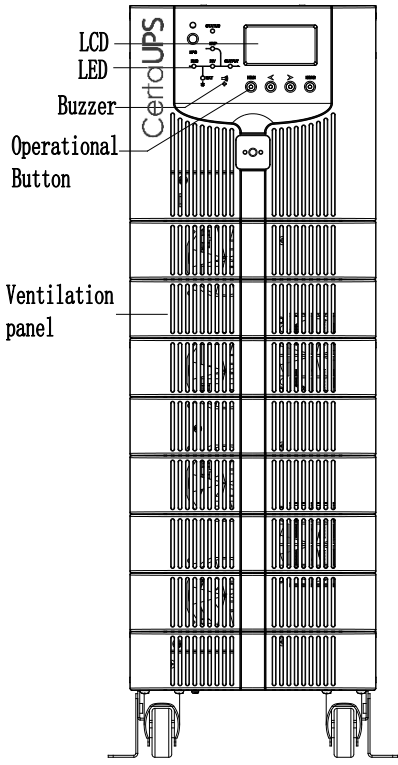

Fig. 2-9 20-30kVA front appearance

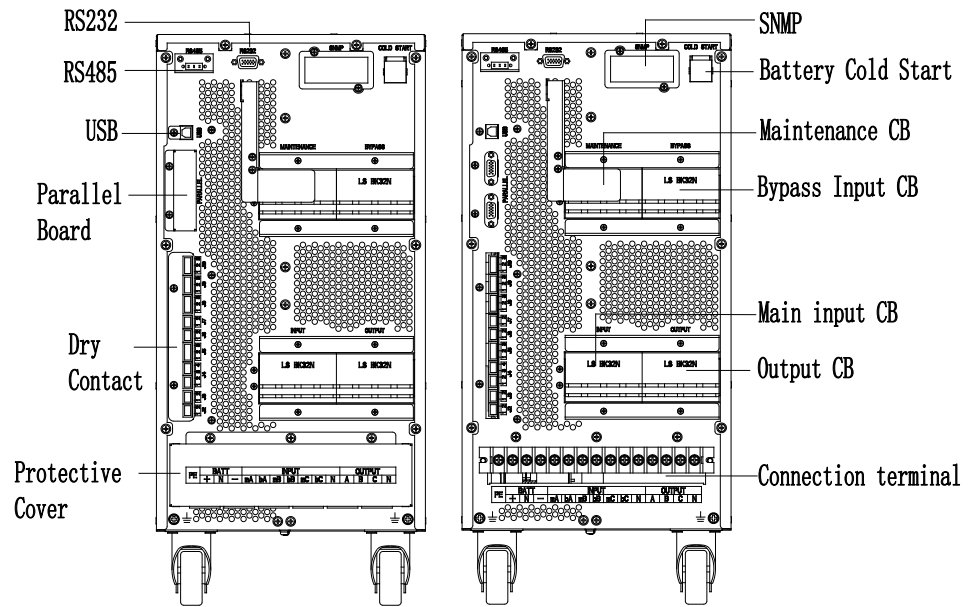

Fig. 2-10 10/15 kVA back appearance

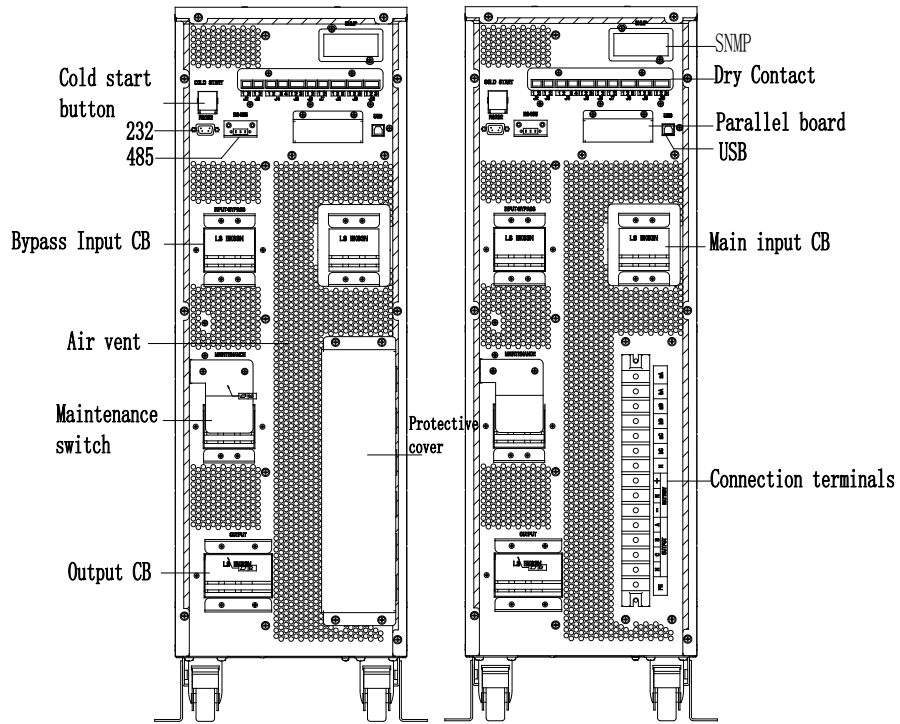

Fig. 2-11 20/30kVA back appearance

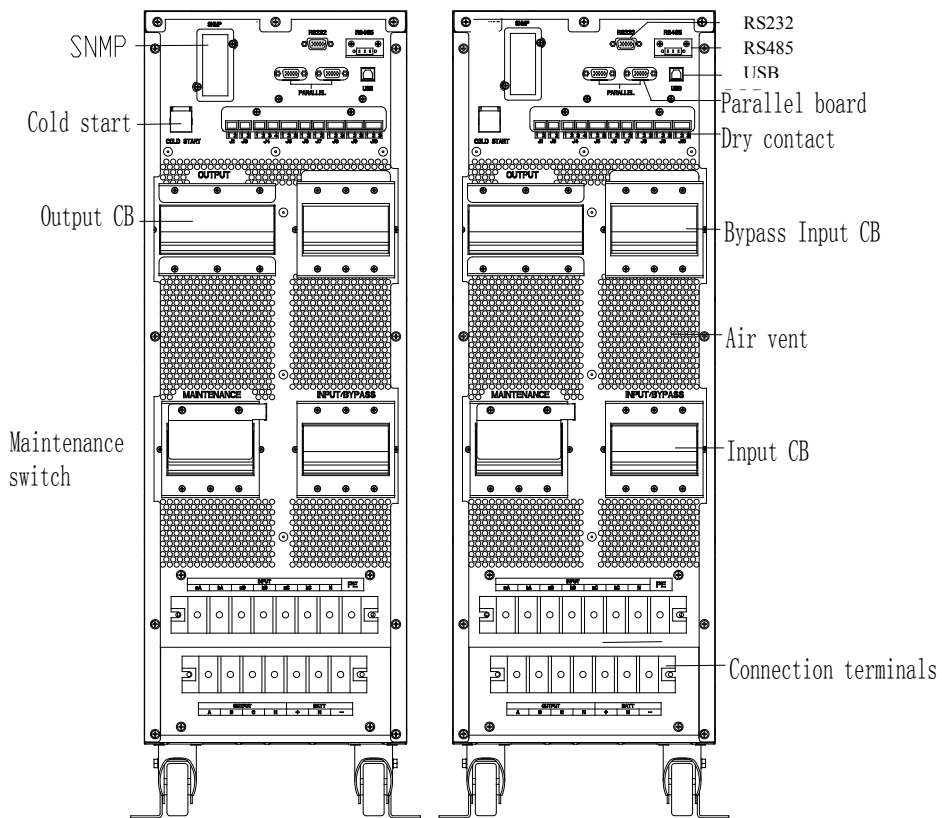

Fig. 2-12 40kVA long type back appearance

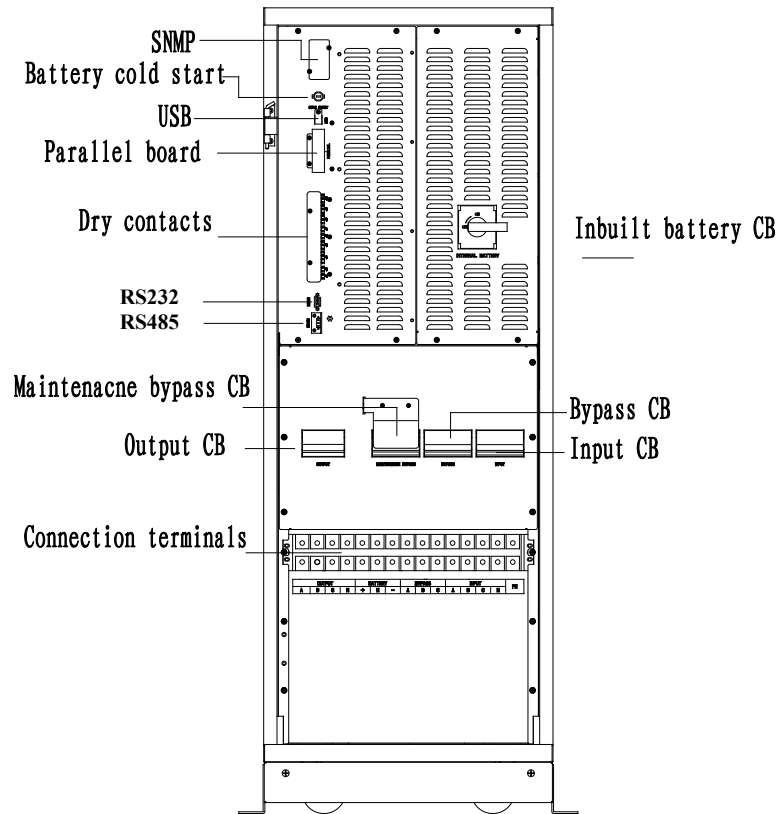

Fig.2-13 40kVA standard type front appearance

3. Installation Instruction

3.1 Location

As each site has its own requirements, the installation instructions in this section are to act as a guide for the general procedures and practices that should be observed by the installation engineer.

3.1.1 Installation Environment

- The UPS is intended for indoor installation and uses forced convection cooling by internal fans. Please make sure there is enough space for the UPS ventilation and cooling.
- Keep the UPS far away from water, heat, flammable, explosive, corrosive material. Avoid installing the UPS in the environment with direct sunlight, dust, volatile gases, corrosive material and high salinity.
- Avoid installing the UPS in the environment with conductive dirt.
- The operating environment temperature for battery is 20°C-25°C. Operating above 25°C will reduce the battery life and operation below 20°C will reduce the battery capacity.
- The battery will generate a little amount of hydrogen and oxygen at the end of charging; ensure the fresh air volume of the battery installation environment must meet EN50272-2001 requirements.
- If external batteries are to be used, the battery circuit breakers (or fuses) must be mounted as close as possible to the batteries, and the connecting cables should be as short as possible.

3.1.2 Site Selection

- Ensure the ground or installation platform can bear the weight of the UPS cabinet, batteries and battery rack.
- No vibration and less than 5 degree inclination horizontally.
- The equipment should be stored in a room so as to protect it against excessive humidity and heat sources.
- The battery needs to be stored in a dry and cool place with good ventilation. The most suitable storage temperature is 20°C-25°C.

3.1.3 Size and Weight

The size of three dimensions for the UPS cabinet is shown in Fig.3-1, 3-2, 3-3



Attention

Ensure there is at least 0.8m before the front of the cabinet so as to easily maintain the power module and at least 0.5m behind for ventilation and cooling. The room reserved for the cabinet is shown in Fig.3-4.

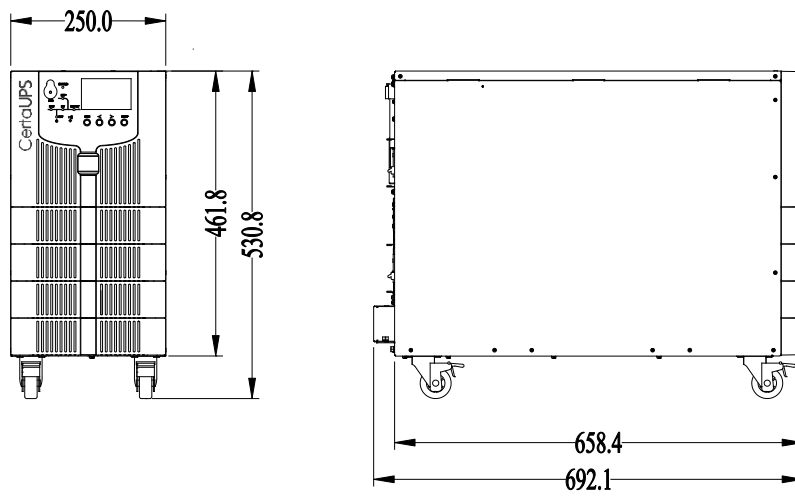

Fig.3-1-1 Size of the 10/15 kVA UPS of Long Backup Type (mm)

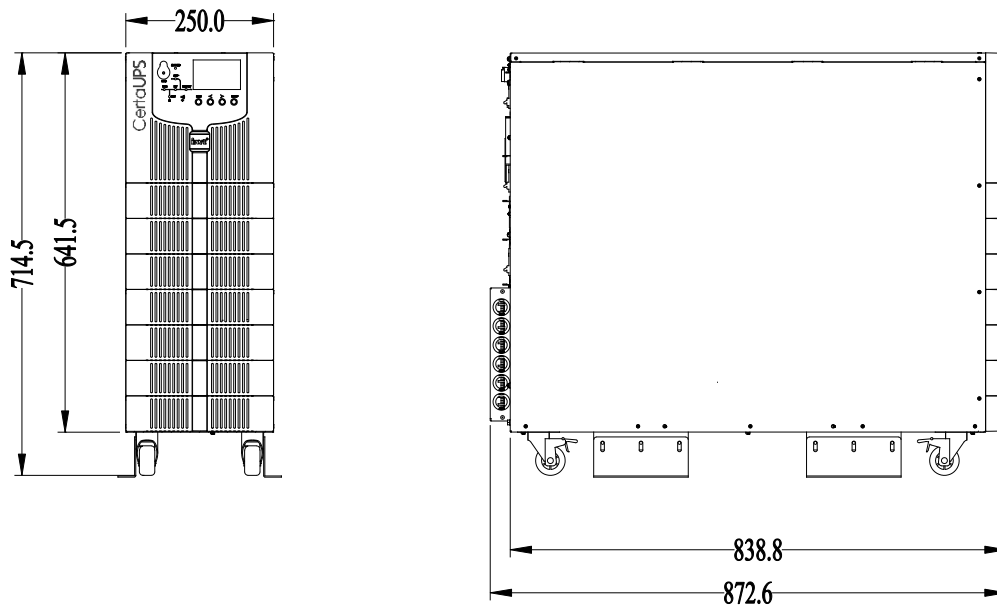

Fig.3-1-2 Size of the 10/15 kVA UPS of Internal battery Type (mm)

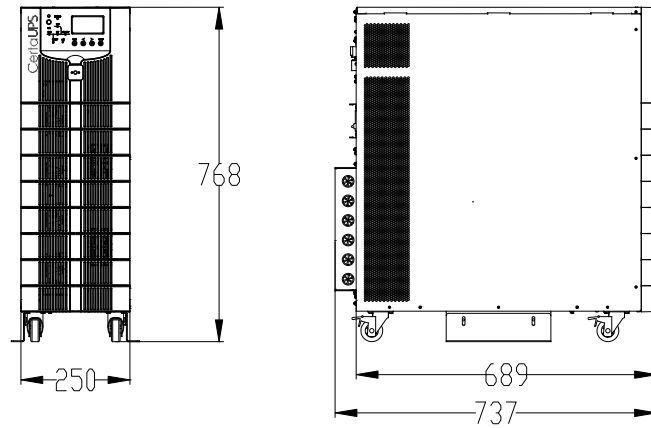

Fig.3-2-1 Size of the 20/30kVA UPS of Long Backup Type (mm)

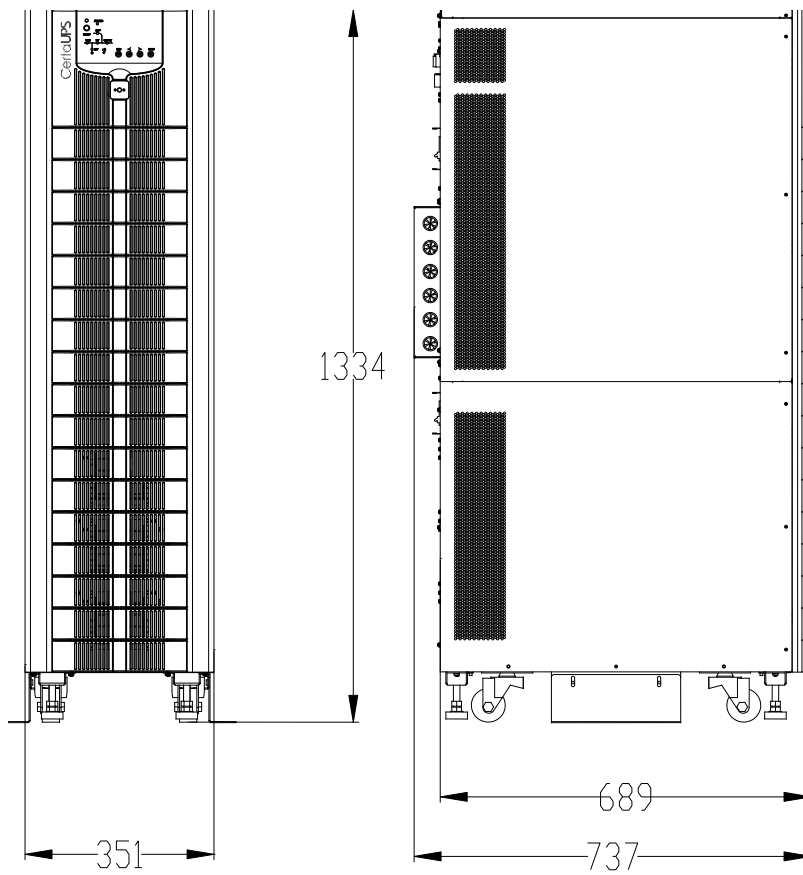

Fig.3-2-2 Size of the 20/30 kVA UPS of internal battery Type (mm)

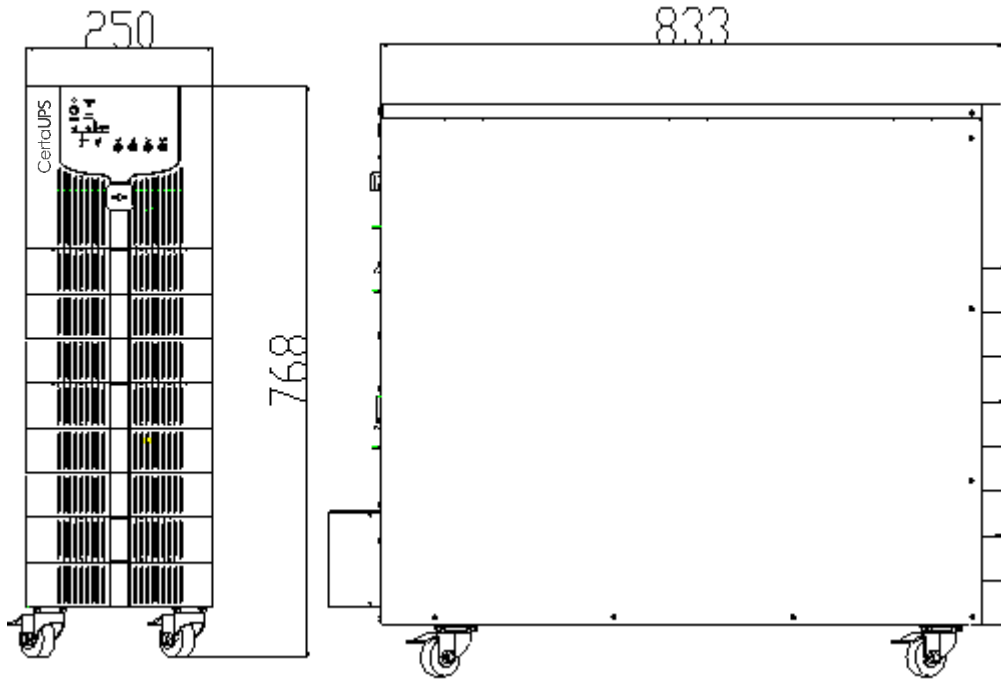

Fig.3-3-1 Size of the 40kVA UPS Long Backup Type (mm)

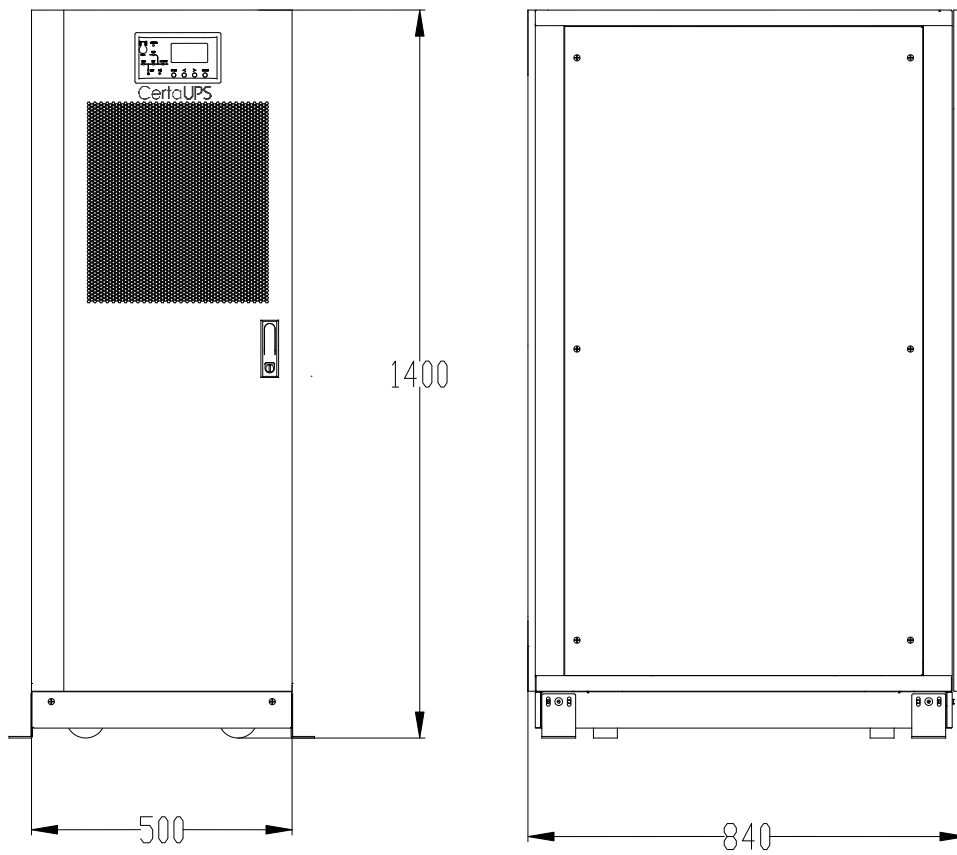

Fig.3-3-2 Size of the 40kVA UPS Standard Type (mm)

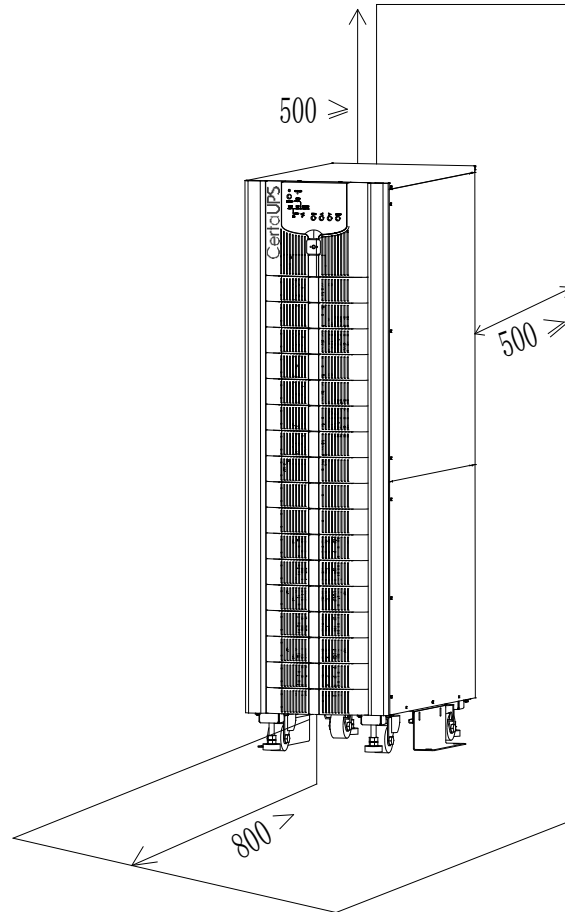

Fig.3-4 Room reserved for the cabinet (mm)

The weight for the UPS cabinet is shown in Table 1.1

Table 1.1 Weight for the cabinet

Configuration	Weight
10kVA/15kVA Standard Backup Type	50kg(No Batteries Included)
10kVA/15kVA Long Backup Type	28kg
20kVA/30kVA Standard Backup Type	88kg(No Batteries Included)
20kVA/30kVA Long Backup Type	50kg
40kVA Long Backup Type	61kg
40kVA standard Type	140kg

3.2 Unloading and Unpacking

3.2.1 Moving and Unpacking of the Cabinet

The steps to move and unpack the cabinet are as follows:

1. Check for damage to the packaging. (If any, contact to the carrier)
2. Transport the equipment to the designated site by forklift, as shown in Fig.3-5.

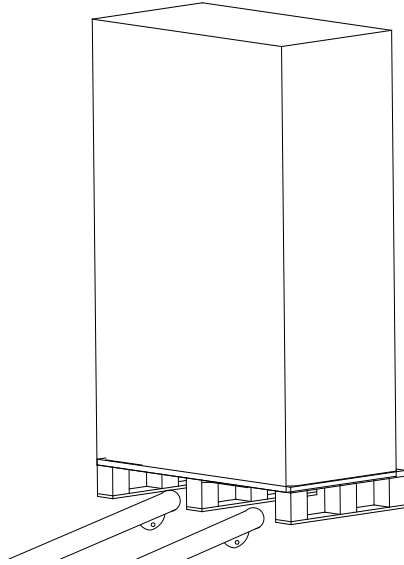

Fig.3-5 Transport to the designated site

3. Unpack the package (see Fig.3-6).

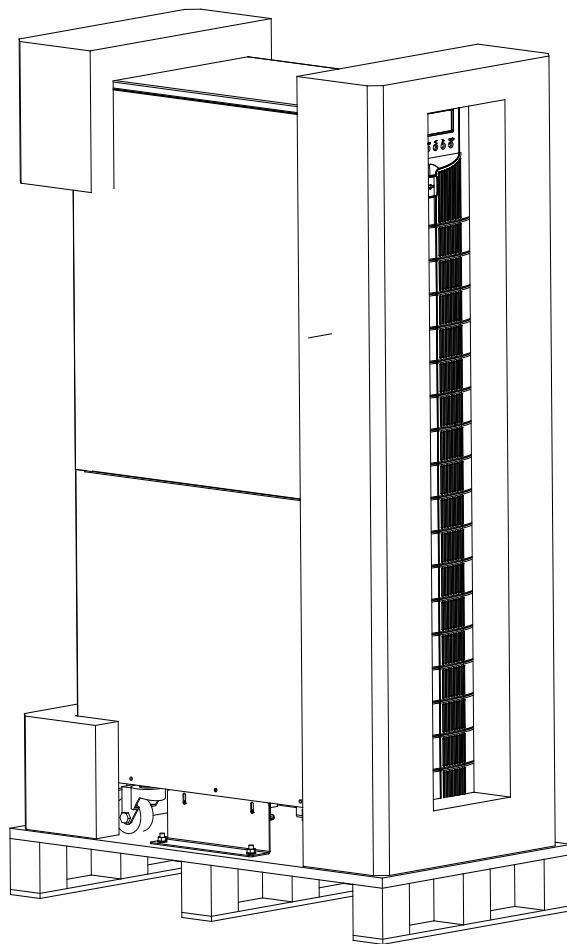

Fig.3-6 Disassemble the case

-
4. Remove the protective foam around the cabinet.

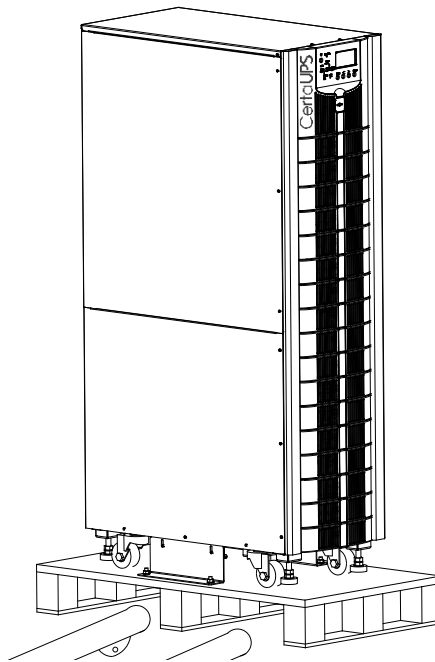

Fig.3-7 Remove the protective foam

5. Check the UPS.
 - (a) Visually examine if there is any damage to UPS during transportation. If damaged contact to the carrier.
 - (b) Check the UPS with the list of the goods. If any items are not included in the list, contact to our company or the local office.
6. Dismantle the bolt that connects the cabinet and wooden pallet after disassembly.
7. Move the cabinet to the installation position.



Attention

Be careful while removing packaging to avoid scratching the equipment.



Attention

The waste packaging materials should be disposed of in accordance with local regulation.

3.3 Positioning

3.3.1 Positioning Cabinet

The UPS cabinet has two ways of supporting its weight: One is to support itself temporarily by the four wheels at the bottom making it convenient to adjust the position of the cabinet. The other is by anchor bolts to support the cabinet permanently after adjusting the position of the cabinet. The supporting structure is shown in Fig. 3-8.

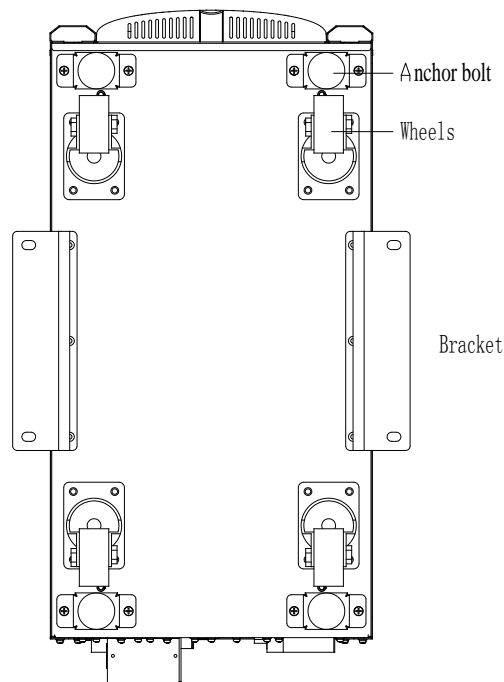

Fig.3-8 Supporting structure (Bottom view)

The steps to position the cabinet are as follows:

1. Ensure the supporting structure is in good condition and the mounting floor is smooth and strong.
2. Retract the anchor bolts by turning them counterclockwise using wrench, the cabinet is then supported by the four wheels.
3. Adjust the cabinet to the right position by the supporting wheels.
4. Put down the anchor bolts by turning them clockwise using a wrench, the cabinet is then supported by the four anchor bolts.
5. Ensure the four anchor bolts are in the same height and the cabinet is fixed and immovable.



Attention

Auxiliary equipment is needed when the mounting floor is not solid enough to support the cabinet, which helps distribute the weight over a larger area. For instance, cover the floor with iron plate or increase the supporting area of the anchor bolts.

3.4 Battery

Three terminals (positive, neutral, negative) are drawn from the battery unit and connected to the UPS system. The neutral line is drawn from the middle of the batteries in series (See Fig.3-9).

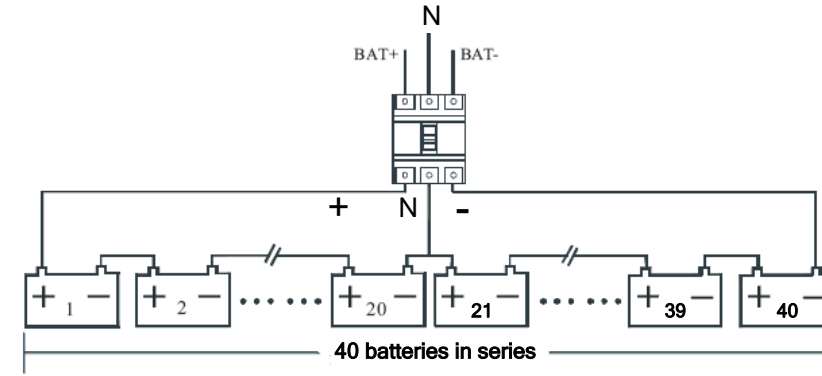

Fig 3-9 Battery string wiring diagram



Danger

The battery terminal voltage is of more than 200VDC, please follow the safety instructions to avoid electric shock hazard.

Ensure the positive, negative, neutral electrode is correctly connected from the battery unit terminals to the breaker and from the breaker to the UPS system.

3.5 Cable Entry

Cables can enter the UPS cabinet from the side or from the bottom. Cable entry is made possible through a blanking plate fitted at the bottom of the equipment. The cable entry is shown in Fig.3-10.

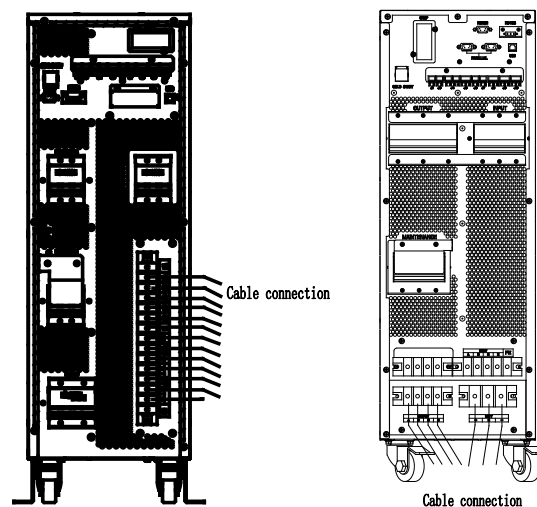

Fig.3-10 Cable entry

3.6 Power Cables

3.6.1 Specifications

The UPS power cables are recommended in Table 3.2.

Table 3.2 Recommended cables for power cables

Contents		10/15kVA	20/30kVA	40kVA	
Main Input	Main Input Current(A)	18/28	35/55	70	
	Cable Section (mm ²)	A	6	10	16
		B	6	10	16
		C	6	10	16
		N	6	10	16
Main Output	Main Output Current(A)	15/23	30/45	60	
	Cable Section (mm ²)	A	6	10	16
		B	6	10	16
		C	6	10	16
		N	6	10	16
Bypass Input (Optional)	Bypass Input Current(A)	15/23	30/45	60	
	Cable Section (mm ²)	A	6	10	16
		B	6	10	16
		C	6	10	16
		N	6	10	16
Battery Input	Battery Input current(A)	20/30	40/60	80	
	Cable Section (mm ²)	+	8	16	25
		-	8	16	25
		N	8	16	25
PE	Cable Section (mm ²)	PE	6	10	16

 **Note**

The recommended cable section for power cables are only for situations described below :

- Ambient temperature, 30 °C.
- AC loss less than 3%, DC loss less than 1%, The length of the AC power cables are no longer than 50 m and the length of the DC power cables are no longer than 30 m.
- Currents listed in the table are based on the 208V system (Line-to-line voltage).
- The size of neutral lines should be 1.5-1.7 times the value listed above when the predominant load is non-linear.

3.6.2 Specifications for Power Cables Terminal

Specifications for power cable connectors are listed as Table 3.3.

Table 3.3 Requirements for power module terminal

Port	Connection	Bolt	Bolt Aperture	Torque Moment
Mains Input	Cables crimped OT terminal	M6	7mm	4.9Nm
Bypass Input	Cables crimped OT terminal	M6	7mm	4.9Nm
Battery Input	Cables crimped OT terminal	M6	7mm	4.9Nm
Output	Cables crimped OT terminal	M6	7mm	4.9Nm
PE	Cables crimped OT terminal	M6	7mm	4.9Nm

3.6.3 Circuit Breaker

The circuit breakers (CB) for the system are recommended in Table 3.4.

Table 3.4 Recommended CB

Installed position	10/15kVA	20kVA	30kVA	40kVA
Battery CB	32A,250VDC	50A,250VDC	63A,250VDC	100A,250VDC



Attention

The CB with RCD (Residual Current Device) is not suggested for the system.

3.6.4 Connecting Power Cables

The steps of connecting power cables are as follows:

1. Verify that all the switches of the UPS are completely open and the UPS internal maintenance bypass switch is open. Attach necessary warning signs to these switches to prevent unauthorised operation.
2. Open the back door of the cabinet, remove the plastic cover. The input and output terminal, battery terminal and protective earth terminal are shown in Fig.3-12 & Fig 3.13.
- 3.

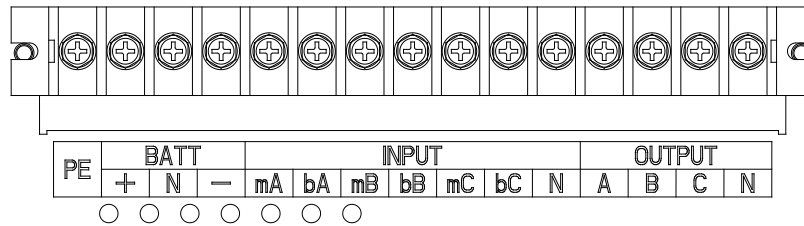

Fig.3-11 connections terminals for 10/15kVA

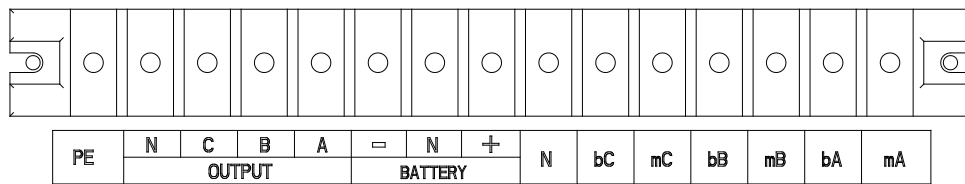

Fig.3-12 connections terminals for 20/30kVA

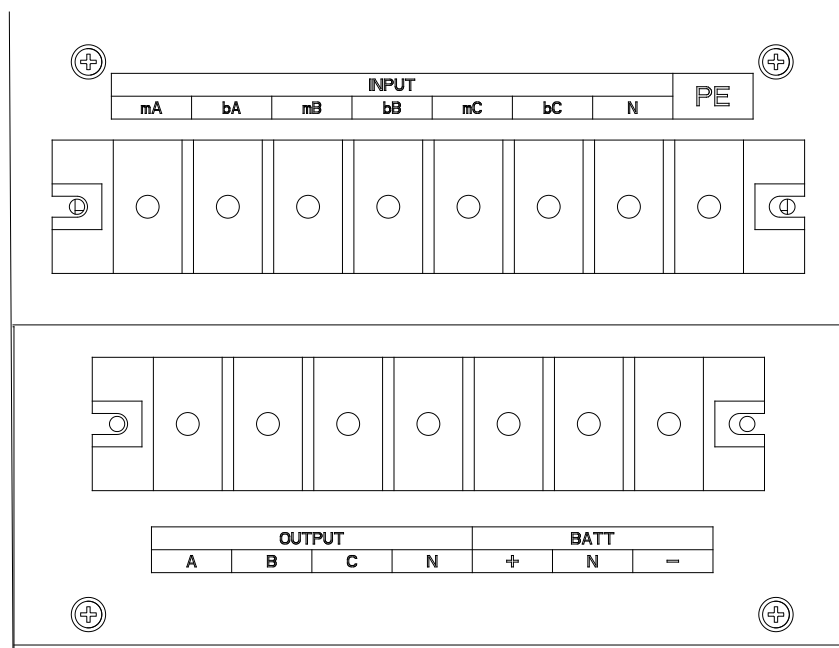

Fig.3-13 connections terminals for 40kVA

4. Connect the protective earth wire to protective earth terminal (PE).

-
5. Connect the AC input supply cables to the Input terminal and AC output supply cables to the Output terminal.
 6. Connect the Battery cables to the Battery terminal.
 7. Check to make sure there are no mistakes and re-install all the protective covers.
- Note: mA, mB, mC standard for Main input phase A,B and C; bA, bB, bC standard for Bypass Input phase A,B and C.**
-



Attention

The operations described in this section must be performed by authorised electricians or qualified technical personnel. If you have any difficulties, contact the manufacturer or agency.



Warning

- Tighten the connections terminals to enough torque, refer to Table 3.3 and please ensure correct phase rotation.
 - The grounding cable and neutral cable must be connected in accordance with local regulations.
 - When the cable holes are not used they should be filled by a hole stopper.
-

3.7 Control and Communication Cables

The front panel of the bypass module provides dry contact interface (J2-J11) and communication interface (RS232, RS485, SNMP, Intelligent card interface and USB port), as it is shown in Fig.3-13.

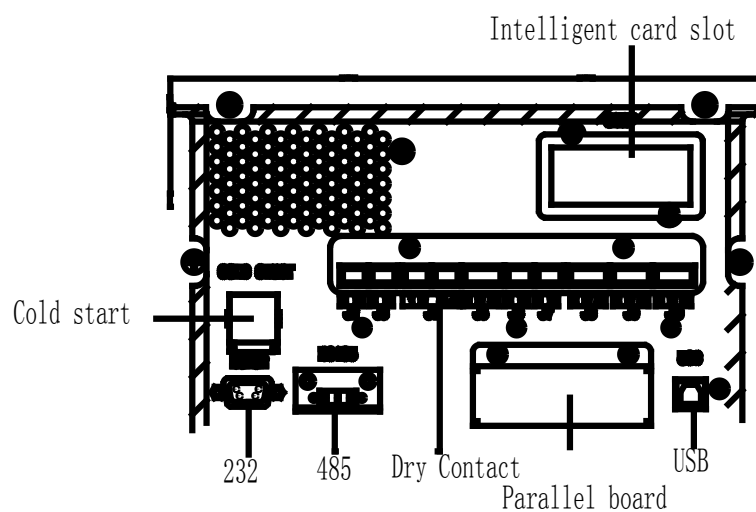

Fig.3-13 Dry contact & communication interface

3.7.1 Dry Contact Interface

Dry contact interface includes ports J2-J11 and the functions of the dry contact are shown in Table 3.5.

Table 3.5 Functions of the port

Port	Name	Function
J2-1	TEMP_BAT	Detection of battery temperature
J2-2	TEMP_COM	Common terminal for temperature detection
J3-1	ENV_TEMP	Detection of environmental temperature
J3-2	TEMP_COM	Common terminal for temperature detection
J4-1	REMOTE_EPO_NC	Trigger EPO when disconnect with J4-2
J4-2	+24V_DRY	+24V
J4-3	+24V_DRY	+24V
J4-4	REMOTE_EPO_NO	Trigger EPO when shorted with J4-3
J5-1	+24V_DRY	+24V
J5-2	GEN_CONNECTED	Input dry contact , function is settable , Default: interface for generator
J5-3	GND_DRY	Ground for +24V
J6-1	BCB Drive	Output dry contact, function is settable. Default: Battery trip signal
J6-2	BCB_Status	Input dry contact, function is settable. Default: BCB Status and BCB Online, (Alert no battery when BCB Status is invalid).
J7-1	GND_DRY	Ground for +24V
J7-2	BCB_Online	Input dry contact, function is settable. Default: BCB Status and BCB Online (Alert no battery when BCB Status is invalid).
J8-1	BAT_LOW_ALARM_NC	Output dry contact (Normally closed), function is settable. Default: Low battery alarming
J8-2	BAT_LOW_ALARM_NO	Output dry contact (Normally open), function is settable. Default: Low battery alarming
J8-3	BAT_LOW_ALARM_GND	Common terminal for J8-1 and J8-2
J9-1	GENERAL_ALARM_NC	Output dry contact, (Normally closed) function is settable. Default: Fault alarming
J9-2	GENERAL_ALARM_NO	Output dry contact, (Normally open) function is settable. Default: Fault alarming
J9-3	GENERAL_ALARM_GND	Common terminal for J9-1 and J9-2
J10-1	UTILITY_FAIL_NC	Output dry contact, (Normally closed) function is settable. Default: Utility abnormal alarming
J10-2	UTILITY_FAIL_NO	Output dry contact, (Normally open) function is settable. Default: Utility abnormal alarming
J10-3	UTILITY_FAIL_GND	Common terminal for J10-1 and J10-2

**Note**

The settable functions for each port can be set by the monitoring software.
The default functions of each port are described as follows.

Battery Warning Output Dry Contact Interface

The input dry contact J2 and J3 can detect the temperature of batteries and environment respectively, which can be used in environment monitoring and battery temperature compensation.

Interfaces diagram for J2 and J3 are shown in Fig.3-14, the description of interface is in Table 3.6.

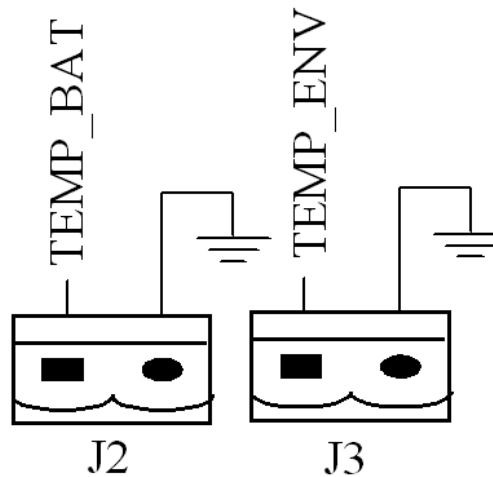

Fig.3-14 J2 and J3 for temperature detecting

Table 3.6 Description of J2 and J3

Port	Name	Function
J2-1	TEMP_BAT	Detection of battery temperature
J2-2	TEMP_COM	common terminal
J3-1	ENV_TEMP	Detection of environmental temperature
J3-2	TEMP_COM	common terminal

**Note**

Specified temperature sensor is required for temperature detection ($R_{25}=5K\Omega$, $B_{25/50}=3275$), please confirm with the manufacturer or contact the local maintenance engineers when placing an order.

Remote EPO Input Port

J4 is the input port for remote EPO. It requires shorting NC and +24V and disconnecting NO and +24V during normal operation. The EPO is triggered when opening NC and +24V or shorting the NO and +24V. The port diagram is shown in Fig.3-15 and port description is shown in Table 3.7.

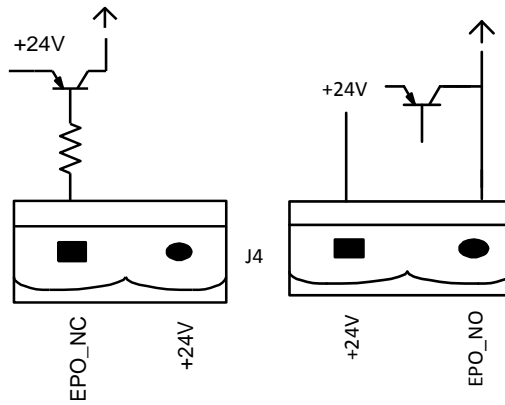

Fig.3-15 Diagram of input port for remote EPO

Table 3.7 Description of input port for remote EPO

Port	Name	Function
J4-1	REMOTE_EPO_NC	Trigger EPO when disconnect with J4-2
J4-2	+24V_DRY	+24V
J4-3	+24V_DRY	+24V
J4-4	REMOTE_EPO_NO	Trigger EPO when connect with J4-3

Generator Input Dry Contact

The default function of J5 is the interface for generator J5 Connect pin 2 of J5 with +24V power supply; it indicates that the generator has been connected with the system. The interface diagram is shown in Fig.3-16, and interface description is shown in Table 3.8.

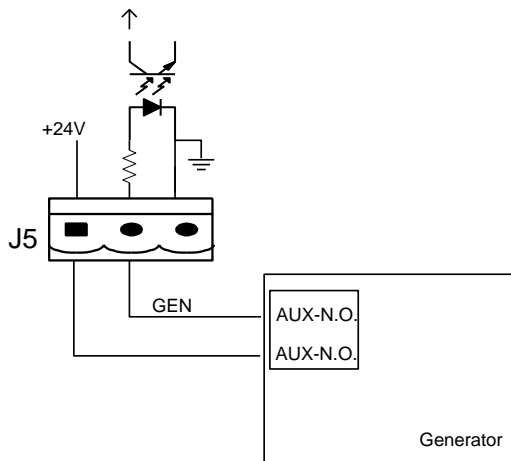

Fig. 3-16 Diagram of status interface and connection of generator

Table 3.8 Description of status interface and connection of generator

Port	Name	Function
J5-1	+24V_DRY	+24V
J5-2	GEN_CONNECTED	Connection status of generator
J5-3	GND_DRY	Power ground for +24V

BCB Input Port

The default function of J6 and J7 are the ports of BCB. The port diagram is shown in Fig.3-17 and description is shown in Table 3.9.

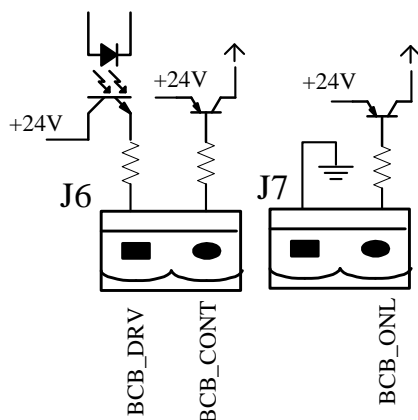

Fig.3-17 BCB Port

Table 3.9 Description of BCB port

Port	Name	Function
J6-1	BCB_DRIV	BCB contact drive, provides +24V voltage, 20mA drive signal
J6-2	BCB_Status	BCB contact status, connect with the normally open signal of BCB
J7-1	GND_DRY	Power ground for +24V
J7-2	BCB_Online	BCB on-line input (normally open), BCB is on-line when the signal is connecting with J7-1

Battery Warning Output Dry Contact Interface

The default function of J8 is the output dry contact interface which presents the battery warnings of low or excessive voltage when the battery voltage is lower than set value. An auxiliary dry contact signal will be activated via the isolation of a relay. The interface diagram is shown in Fig.3-18, and description is shown in Table 3.10.

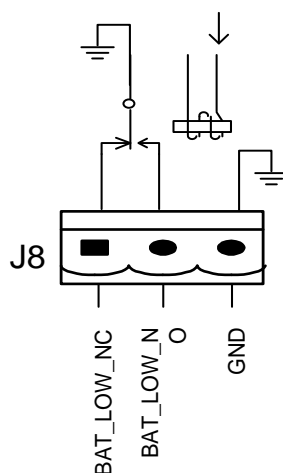

Fig.3-18 Battery warning dry contact interface diagram

Table3.10 Battery warning dry contact interface description

Port	Name	Function
J8-1	BAT_LOW_ALARM_NC	Battery warning relay (normally closed) will be open during warning
J8-2	BAT_LOW_ALARM_NO	Battery warning relay (normally open) will be closed during warning
J8-3	BAT_LOW_ALARM_GND	Common terminal

General Alarm Output Dry Contact Interface

The default function of J9 is the general alarm output dry contact interface. When one or more warnings are triggered, an auxiliary dry contact signal will be active via the isolation of a relay. The interface diagram is shown in Fig.3-19 and description is shown in Table 3.11.

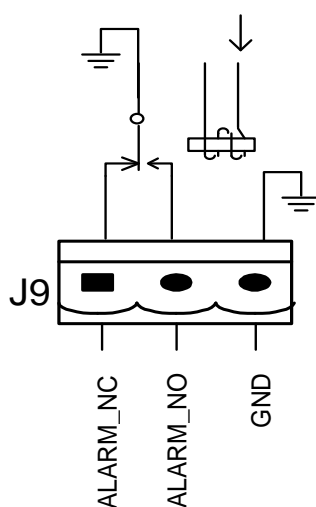

Fig.3-19 Integrated dry contact warning interface diagram

Table3.11 General alarm dry contact interface description

Port	Name	Function
J9-1	GENERAL_ALARM_NC	Integrated warning relay (normally closed) will be open during warning
J9-2	GENERAL_ALARM_NO	Integrated warning relay (normally open) will be closed during warning
J9-3	GENERAL_ALARM_GND	Common terminal

Utility Fail Warning Output Dry Contact Interface

The default function of J10 is the output dry contact interface for utility failure warning. When the utility fails the system will send a utility failure warning information and provide an auxiliary dry contact signal via the isolation of a relay. The interface diagram is shown in Fig.3-20, and description is shown in Table 3.12.

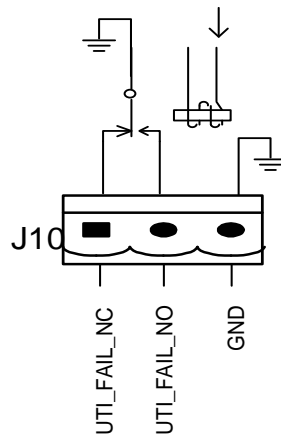

Fig.3-20 Utility failure warning dry contact interface diagram

Table 3.12 Utility failure warning dry contact interface description

Port	Name	Function
J10-1	UTILITY_FAIL_NC	Mains failure warning relay(normally closed) will be open during warning
J10-2	UTILITY_FAIL_NO	Mains failure warning relay (normally open) will be closed during warning
J10-3	UTILITY_FAIL_GND	Common terminal

3.7.2 Communication Interface

RS232, RS485 and USB port: Provide serial data which can be used for commissioning and maintenance by authorised engineers or can be used for networking or integrated monitoring system in the server room.

NOTE: *SNMP: Used on site installation for communication (Optional).*

Intelligent card interface: Extension dry contact interface (Optional).

4. LCD Panel

4.1 Introduction

This chapter introduces the functions and operator instructions of the control and display panel in detail. The LCD displays information, including LCD display types, detailed menu information, prompt information and UPS alarm information.

4.2 LCD panel for C800 CertaUPS

The structure of operator control and display panel for the UPS is shown in Fig.4-1.

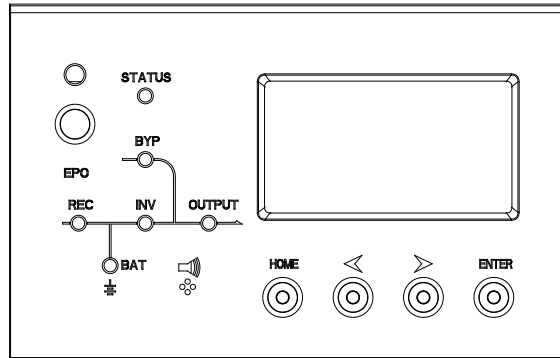

Fig.4-1 Control and display panel for C800 UPS

The LCD panel for the UPS is divided into three functional areas: LED indicator, control and operation keys and LCD screen.

4.2.1 LED Indicator

There are 6 LEDs on the panel to indicate the operating status and fault. (See Fig.4-1).The description of indicators is shown in Table 4.1

Table 4.1 Status description of indicators

Rectifier indicator	Steady green	Rectifier normal for all modules
Battery indicator	Flashing green	Rectifier normal for at least one module, mains normal
	Steady red	Rectifier fault
	Flashing red	Mains abnormal for at least one module
	Off	Rectifier not operating
	Steady green	Battery charging
Bypass indicator	Flashing green	Battery discharging
	Steady red	Battery abnormal (battery failure, no battery or battery reversed) or battery converter abnormal (failure, over current or over temperature) , EOD
	Flashing red	Battery low voltage
	Off	Battery and battery converter normal, battery not charging
	Steady green	Load supplied by bypass
	Steady red	Bypass abnormal or out of normal range or static bypass switch fault
	Flashing red	Bypass voltage abnormal
Inverter indicator	Off	Bypass normal
	Steady green	Load supplied by inverter
	Flashing green	Inverter on, start, synchronisation or standby (ECO mode) for at least one module
	Steady red	System output not supplied by inverter, inverter fault for at least one module.
	Flashing red	System output supplied by inverter, inverter fault for at least one module.
Load indicator	Off	Inverter not operating for all modules
	Steady green	UPS output ON and normal
	Steady red	UPS overload time is out, or output short, or output no power supply
	Flashing red	Overload output of UPS
Status indicator	Off	No output of UPS
	Steady green	Normal operation
	Steady red	Failure

There are two different types of audible alarm during UPS operation, as shown in Table 4.2.

Table 4.2 Description of audible alarm

Alarm	Description
Two short alarms with a long one	When system has general alarm (for example: AC fault)
Continuous alarm	When system has serious faults (for example: fuse or hardware fault)

4.2.2 Control and Operation Keys

Control and operation keys include four keys, which are used together with LCD screen. The functions description is shown in Table 4.3.

Table 4.3 Functions of Control and operation keys

Function Key	Description
EPO	Long press, cut off the load power (shutdown the rectifier, inverter, static bypass and battery)
TAB	Transfer
ENTER	Confirm
ESC	Quit



Attention

When bypass frequency is out of tolerance, there is interruption time (less than 10ms) for transferring from bypass to inverter.

4.2.3 LCD Screen

After the initial power on self test, the system enters the home page following the welcome window. The home page is shown in Fig.4-2.

Home page consists of System Information Window, Menu Window and Current Command and Record Menu.

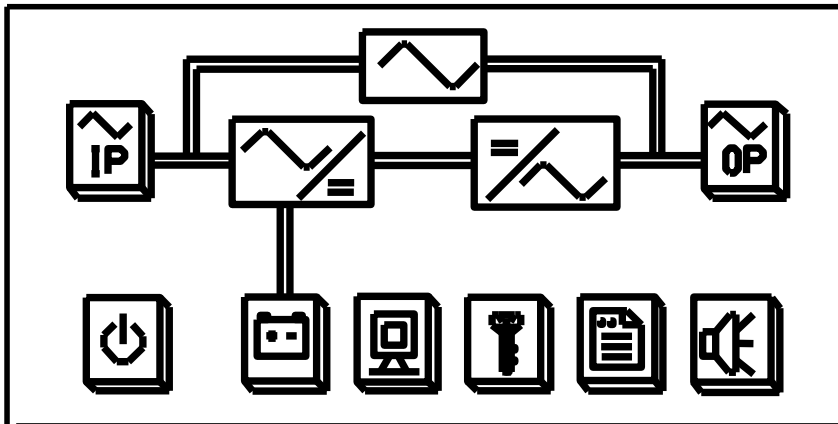



Fig.4-2 Home page

The description of LCD icons is shown in Table 4.4.

Table 4.4 Description of LCD Icons

Icon	Description
	Power On/Off button
	Parameters of Main & Bypass Input
	History log
	Function set(Fault Clear, Battery Test, Battery Maintenance, Language Set, Manual Transfer, etc.), System Configuration(For Service Engineer Only)
	Parameters of Battery, DC bus information, Temperature etc.
	Parameters of Output & Load
	Warning, S-code and System Information(Rated parameters, Version Information)
	Mute on/off
	Page Up & Down

Select the icon, and the system enters the corresponding page; take the icon  (Main Input) for example, as shown in Fig.4-3.





HOME 	I/P MAIN	 NEXT
A	B	C
220.1 V	220.1 V	220.1 V
45.0 A	45.0 A	45.0 A
50.01 Hz	50.01 Hz	50.01 Hz
0.99 PF	0.99 PF	0.99 PF

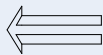

Fig.4-3 Main input page

Select the icon  and it will display the information of the batteries, as shown in Fig.4-4.

HOME 	BATTERY P.1	 NEXT
Batt Volt	240.0 V	240.0 V
Batt Curr	5.0 A	5.0 A
Batt Number	40	
Dischag Times	10	
Status	Batt Boost	

Fig

4-4 Battery Information

- Select , to view the current status of the UPS
- Select , to turn off the buzzer raising from general alarms;
- Select , to view the system information and maintenance code;

 **Note**

The LCD will go to sleep after 2 minutes if there are no warnings or faults. Press any button to wake the screen up.

4.3 System Information Window

System Information Window displays the current time and UPS model as is shown in the following Table 4.5.

Table 4.5 Description of System Information Window

Content	Description
3320S	UPS mode:3-phase in 3-phase out 20kVA,standard backup type
16:30	Current time

4.4 Menu Window

The Menu options display the various menus available while the data screens display the related values of the selected menu. Navigating the menus and related parameters allow the functions of the UPS to be configured. Details are given in Table 4.6.

Table.4.6 Description of UPS Menu

Menu name	Menu item	Meaning
Main input	V phase(V)	Voltage
	I phase(A)	Current
	Freq.(Hz)	Frequency
	PF	Power factor
Bypass input	V phase(V)	Voltage
	Freq. (Hz)	Frequency
	I phase(A)	Current
	PF	Power factor
Output	V phase(V)	Voltage
	I phase(A)	Current
	Freq. (Hz)	Frequency
	PF	Power factor
UPS module load	Sout (kVA)	Apparent Power
	Pout (kW)	Active Power
	Qout (kVAR)	Reactive Power
	Load (%)	Load percent
Battery data	Environmental Temp	Environmental Temp
	Battery Voltage(V)	Positive and negative battery voltage
	Battery Current A)	Positive and negative battery current
	Battery Temp(°C)	Battery Temperature
	Remaining Time (Min.)	Remained battery backup time
	Battery capacity (%)	Remained battery capacity
	Battery Boost Charging	Battery is working in boost charging mode
	Battery float charging	Battery is working in float charging mode
	Battery Disconnected	Battery is not connected
Current alarm	Display all current alarm. The alarms are displayed on LCD	

Menu name	Menu item	Meaning
History log		Display all history logs.
Function Settings	Display calibration	Adjust the accuracy of LCD display
	Date format set	MONTH-DATE-YEAR and YEAR-MONTH-DATE formats can be selected
	Date & Time	Date/Time set
	Language set	User can set the language
	Communication set	/
	Control password 1 set	User can modify control password 1
Command	Battery maintenance test	This test will lead to the battery being partly discharged to activate battery until battery voltage is low. Bypass must be in normal condition, the battery capacity should be above 25%.
	Battery self-check test	UPS transfer to battery discharge mode to test if the battery is normal. Bypass must be in normal condition, the battery capacity should be above 25%.
	Stop testing	Manually Stop the test including maintenance test, capacity test
UPS system information	Monitoring software version	Monitoring software version
	Rectified software version	Rectifier software version
	Inverted software version	Inverter software version
	Serial No.	The serial NO set when delivered from the factory
	Rated information	System rated information
	Module model	Module model

4.5 Event List

The following Table4.7 gives events of UPS History Log

Table 4.7 List of History Log

String Sequence	LCD Display	Explanation
1	Load On UPS-Set	Load On UPS
2	Load On Bypass-Set	Load On Bypass
3	No Load-Set	No Load (Output Power Lost)
4	Battery Boost-Set	Charger is Boosting Battery Voltage
5	Battery Float-Set	Charger is Floating Battery Voltage
6	Battery Discharge-Set	Battery is Discharging
7	Battery Connected-Set	Battery cables Connected
8	Battery Not Connected-Set	Battery cables Disconnected.
9	Maintenance CB Closed-Set	Maintenance CB is Closed
10	Maintenance CB Open-Set	Maintenance CB is Open

11	EPO-Set	Emergency Power Off
12	Module On Less-Set	Valid Inverter capacity is less than the load capacity
13	Module On Less-Clear	Incident above disappears
14	Generator Input-Set	Generator as the Ac Input Source
15	Generator Input-Clear	Incident above disappears
16	Utility Abnormal-Set	Utility (Grid) Abnormal
17	Utility Abnormal-Clear	Incident above disappears
18	Bypass Sequence Error-Set	Bypass voltage Sequence is reverse
19	Bypass Sequence Error-Clear	Incident above disappears
20	Bypass Volt Abnormal-Set	Bypass Voltage Abnormal
21	Bypass Volt Abnormal-Clear	Incident above disappears
22	Bypass Module Fail-Set	Bypass Module Fail
23	Bypass Module Fail-Clear	Incident above disappears
24	Bypass Overload-Set	Bypass Over load
25	Bypass Overload-Clear	Incident above disappears
26	Bypass Overload Tout-Set	Bypass Over Load Timeout
27	Byp Overload Tout-Clear	Incident above disappears
28	Byp Freq Over Track-Set	Bypass Frequency Over Track Range
29	Byp Freq Over Track-Clear	Incident above disappears
30	Exceed Tx Times Lmt-Set	Transfer times (from inverter to bypass) in 1 hour exceed the limit.
31	Exceed Tx Times Lmt-Clear	Incident above disappears
32	Output Short Circuit-Set	Output shorted Circuit
33	Output Short Circuit-Clear	Incident above disappears
34	Battery EOD-Set	Battery End Of Discharge
35	Battery EOD-Clear	Incident above disappears
36	Battery Test-Set	Battery Test Starts
37	Battery Test OK-Set	Battery Test OK
38	Battery Test Fail-Set	Battery Test fails
39	Battery Maintenance-Set	Battery Maintenance Starts
40	Batt Maintenance OK-Set	Battery maintenance succeeds
41	Batt Maintenance Fail-Set	Battery maintenance fails
42	Module Inserted-Set	N# Power Module joins the system
43	Module Exit-Set	N# Power Module quits the system.
44	Rectifier Fail-Set	N# Power Module Rectifier Fails
45	Rectifier Fail-Clear	Incident above disappears
46	Inverter Fail-Set	N# Power Module Inverter Fail
47	Inverter Fail-Clear	Incident above disappears
48	Rectifier Over Temp.-Set	N# Power Module Rectifier Over Temperature

49	Rectifier Over Temp.-Clear	Incident above disappears
50	Fan Fail-Set	N# Power Module Fan Fail
51	Fan Fail-Clear	Incident above disappears
52	Output Overload-Set	N# Power Module Output Over Load
53	Output Overload-Clear	Incident above disappears
54	Inverter Overload Tout-Set	N# Power Module Inverter Over Load Timeout
55	INV Overload Tout-Clear	Incident above disappears
56	Inverter Over Temp.-Set	N# Power Module Inverter Over Temperature
57	Inverter Over Temp.-Clear	Incident above disappears
58	On UPS Inhibited-Set	Inhibit system transfer from bypass to UPS (inverter)
59	On UPS Inhibited-Clear	Incident above disappears
60	Manual Transfer Byp-Set	Transfer to bypass manually
61	Manual Transfer Byp-Set	Cancel to bypass manually
62	Esc Manual Bypass-Set	Escape transfer to bypass manually command
63	Battery Volt Low-Set	Battery Voltage Low
64	Battery Volt Low-Clear	Incident above disappears
65	Battery Reverse-Set	Battery pole (positive and negative are reverse)
66	Battery Reverse-Clear	Incident above disappears
67	Inverter Protect-Set	N# Power Module Inverter Protect (Inverter Voltage Abnormal or Power Back feed to DC Bus)
68	Inverter Protect-Clear	Incident above disappears
69	Input Neutral Lost-Set	Input Grid Neutral Lost
70	Bypass Fan Fail-Set	Bypass Module Fan Fail
71	Bypass Fan Fail-Clear	Incident above disappears
72	Manual Shutdown-Set	N# Power Module Manually Shutdown
73	Manual Boost Charge-Set	Manually Battery Boost Charge
74	Manual Float Charge-Set	Manually Battery Float Charge
75	UPS Locked-Set	Inhibit to shut down the UPS
76	Parallel Cable Error-Set	Parallel cable in error
77	Parallel Cable Error-Clear	Incident above disappears
78	Lost N+X Redundant	Lost N+X Redundant
79	N+X Redundant Lost-Clear	Incident above disappears
80	EOD Sys Inhibited	System is inhibited to supply after the battery is EOD (end of discharging)
81	Power Share Fail-Set	Power share is not in balance
82	Power Share Fail-Clear	Incident above disappears
83	Input Volt Detect Fail-Set	Input Voltage is abnormal
84	Input Volt Detect Fail-Clear	Incident above disappears
85	Battery Volt Detect Fail-Set	Battery Voltage is abnormal

86	Batt Volt Detect Fail-Clear	Incident above disappears
87	Output Volt Fail-Set	Output Voltage is abnormal
88	Output Volt Fail-Clear	Incident above disappears
89	Outlet Temp. Error-Set	Outlet Temperature is abnormal
90	Outlet Temp. Error-Clear	Incident above disappears
91	Input Curr Unbalance-Set	Input current is not balance
92	Input Curr Unbalance-Clear	Incident above disappears
93	DC Bus Over Volt-Set	DC bus over Voltage
94	DC Bus Over Volt-Clear	Incident above disappears
95	REC Soft Start Fail-Set	Rectifier soft start fails
96	REC Soft Start Fail-Clear	Incident above disappears
97	Relay Connect Fail-Set	Relay in open circuit
98	Relay Connect Fail-Clear	Incident above disappears
99	Relay Short Circuit-Set	Relay shorted
100	Relay Short Circuit-Clear	Incident above disappears
101	No Inlet Temp. Sensor-Set	The inlet temperature sensor is not connected or abnormal
102	No Inlet Temp Sensor-Clear	Incident above disappears
103	No Outlet Temp. Sensor-Set	The Outlet temperature sensor is not connected or abnormal
104	No Outlet Temp Sensor-Clear	Incident above disappears
105	Inlet Over Temp.-Set	Inlet over temperature
106	Inlet Over Temp.-Clear	Incident above disappears

5. Operations

5.1 UPS Start-up

5.1.1 Start from Normal Mode

The UPS must be started up by commissioning engineer after completion of the installation. The steps below must be followed:

1. Ensure all the circuit breakers are open.
2. Close the output circuit breaker (CB) and then the input CB and the system starts initialising. If the system has dual inputs, close both of the breakers.
3. The LCD on the front of the UPS is lit up. The system enters the home page, as shown in Fig.4-2.
4. Notice the energy bar in the home page, and pay attention to the LED indicators. The rectifier flashes indicating the rectifier is starting up. The LED indicators are listed below in Table 5.1.

Table 5.1 Rectifier starting up

Indicator	Status	Indicator	Status
Rectifier	green flashing	Inverter	off
Battery	red	Load	off

Indicator	Status	Indicator	Status
Bypass	off	Status	red

5. After 30s, the rectifier indicator goes steady green, indicating the completion of rectifier start-up and bypass static switch closes then the inverter starts up. The LED indicators are listed below in Table.5.2.

Table 5.2 Inverter starting up

Indicator	Status	Indicator	Status
Rectifier	green	Inverter	green flashing
Battery	red	Load	green
Bypass	green	Status	red

6. The UPS transfers from the bypass to inverter after the inverter goes normal. The LED indicators are listed below in Table 5.3.

Table 5.3 Supplying the load

Indicator	Status	Indicator	Status
Rectifier	green	Inverter	green
Battery	red	Load	green
Bypass	off	Status	red

7. The UPS is in Normal Mode. Close the battery circuit breakers and the UPS starts charging the battery. The LED indicators are listed below in Table 5.4.

Table 5.4 Normal mode

Indicator	Status	Indicator	Status
Rectifier	green	Inverter	green
Battery	green	Load	green
Bypass	off	Status	green



Note

When the system starts, the stored setting will be loaded.

Users can browse all incidents during the process of the starting up by checking the menu Log.

5.1.2 Start from Battery

The start for battery mode is referring to battery cold start. The steps for the start-up are as follows:

1. Confirm the batteries are correctly connected, close the external battery circuit breakers.
2. Press the red button for the battery cold start (See Fig.5-1).The system is then powered by the battery.

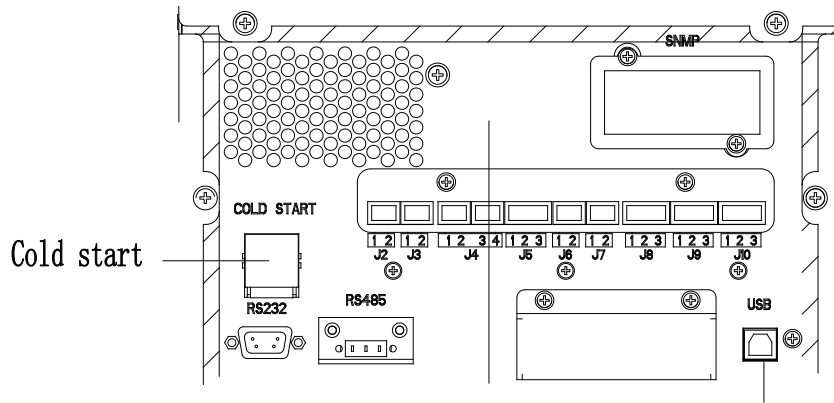

Fig.5-1 the position of the battery cold start button

3. After that, the system will start up following steps 3 in section 5.1.1 and the system transfers to battery mode within 30s.
4. Close the output isolation switch or external output isolation switch to supply the load and the system is working on battery mode.

5.2 Procedure for Switching between Operation Modes

5.2.1 Switching the UPS into Battery Mode from Normal Mode

The UPS transfers to Battery mode immediately after input circuit breaker disconnects from the UPS.

5.2.2 Switching the UPS into Bypass Mode from Normal Mode

Select the  icon and then select **Manual Byp** to transfer the system to Bypass Mode.



Warning

Ensure the bypass is working normally before transferring to bypass mode. Or it may cause failure.

5.2.3 Switching the UPS into Normal Mode from Bypass Mode

Select the  icon and then **Manual ESC**, the system will the transfer to Normal Mode

Note

Normally, the system will transfer to the Normal mode automatically. This function is used when the frequency of the bypass is out of tolerance and when the system needs to transfer to Normal mode by manual operation.

5.2.4 Switching the UPS into Maintenance Bypass Mode from Normal Mode

The following procedure allows you to transfer the load from the UPS inverter output to the maintenance bypass supply which can be used for maintaining the UPS.

1. Transfer the UPS into Bypass mode following section 5.2.2.
2. Remove the maintenance bypass breaker cover.
3. Turn on the maintenance bypass breaker, the load is then powered via maintenance bypass and static bypass.
4. One by one turn off the battery breaker, input breaker, bypass input breaker and output breaker.
5. The load is powered through the maintenance bypass.

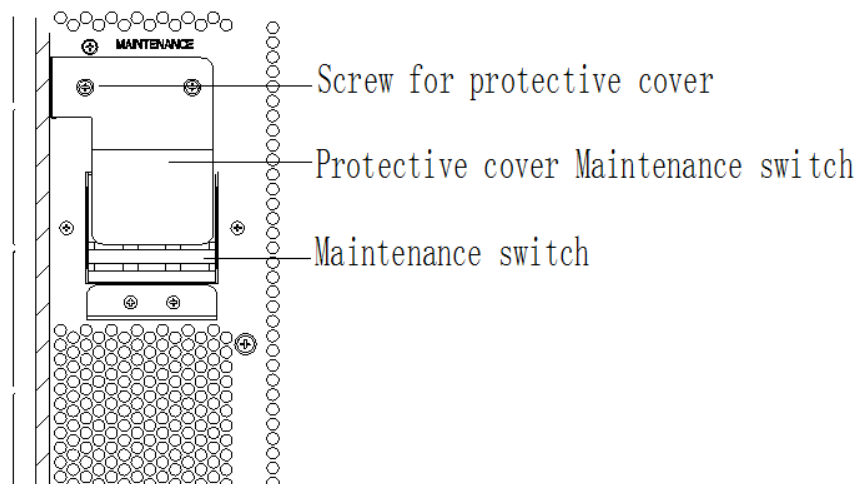

Fig.5-2 the cover of maintenance bypass breaker



Warning

Once the cover on the maintenance bypass breaker is removed, the system will transfer to bypass mode automatically.



Warning

Before making this operation, confirm the messages on LCD display to be sure that bypass supply is regular and the inverter is synchronous with it, so as not to risk a short interruption in powering the load.



Danger

Even with the LCD turned off, the terminals of input and output may be still energized. Wait for 10 minutes to let the DC bus capacitor fully discharge before removing the cover.

5.2.5 Switching the UPS into Normal Mode from Maintenance Bypass Mode

These following procedures can transfer the load from Maintenance Bypass mode to Online mode.

1. After completion of maintenance/servicing, one by one to turn on the output breakers, bypass input breaker, input breaker and battery breaker.
2. After 30s, the bypass indicator LED goes green and the load is powered through the maintenance bypass breaker and static bypass.
3. Turn off the maintenance bypass breaker and fix the protection cover, and then the load is powered through static bypass. The rectifier starts followed by the inverter.
4. After 60s, the system transfers to Normal mode.



Warning

The system will stay on bypass mode until the cover of maintenance bypass breaker is fixed.

5.3 Battery Maintenance

If the battery is not discharged for a long time, it is necessary to test the condition of the battery.

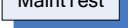

Enter the menu  as is shown in Fig.5-3 and select the icon , the system transfers into the Battery mode for discharging. The system will discharge the batteries until an alarm of “Battery low voltage” is given. Users can stop the

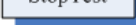
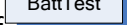
discharging by the “Stop Test” icon . With the icon of , batteries will be discharged for about 30 seconds, and then transfer back to normal mode.

BACK	≡	FUNCTION	≡	END
ManualByp/Esc		Batt. Test		
Fault Clear		Maint Test		
Manual INV		Stop Test		

Fig.5.3 Battery maintenance

5.4 EPO

The EPO button located in the operator control and display panel (with cover to avoid accidental operation, see Fig.5-5) is designed to switch off the UPS in emergency conditions (e.g., fire, flood, etc.). To achieve this simply press the EPO button and the system will turn off the rectifier, inverter and stop powering the load immediately (including the inverter and bypass output). This will also stop the battery charging or discharging. If the mains input is present the UPS control circuit will remain active, however the output will be turned off. To completely isolate the UPS users need to open the external mains input supply to the UPS



Warning

When the EPO is triggered the load is not powered by the UPS. Be careful when using the EPO function.

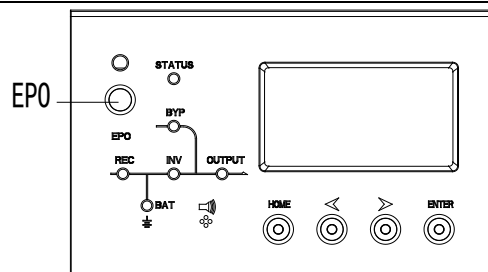

Fig. 5-5 EPO Button

5.5 Installation of Parallel Operation System

5.5.1 Parallel system diagram

Up to ten UPS can be paralleled together. Four UPS in parallel are shown in Fig.5-6.

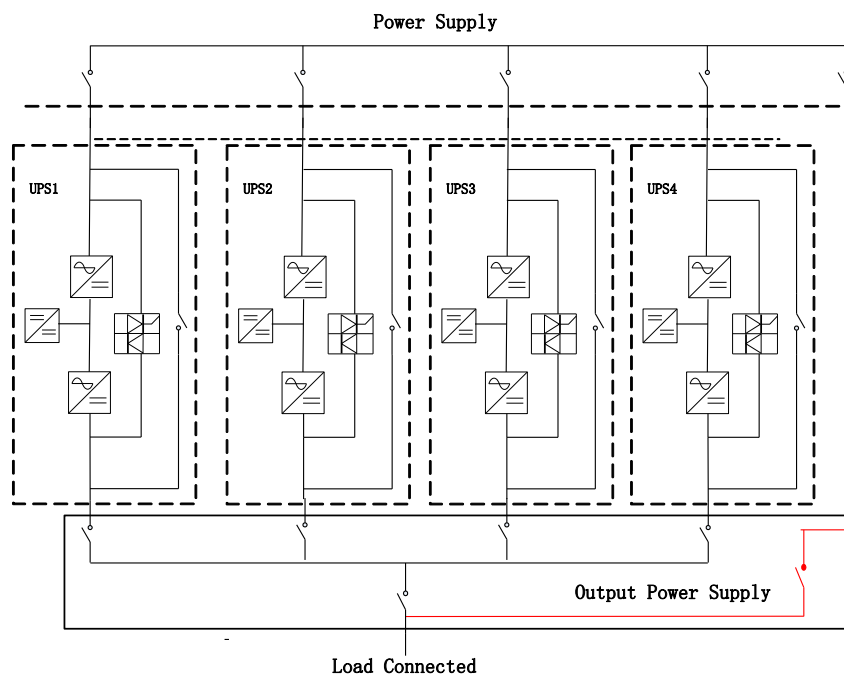

Fig. 5-6 Parallel diagram

The parallel board is located at the back of the UPS cabinet, as is shown in Fig.5-7.

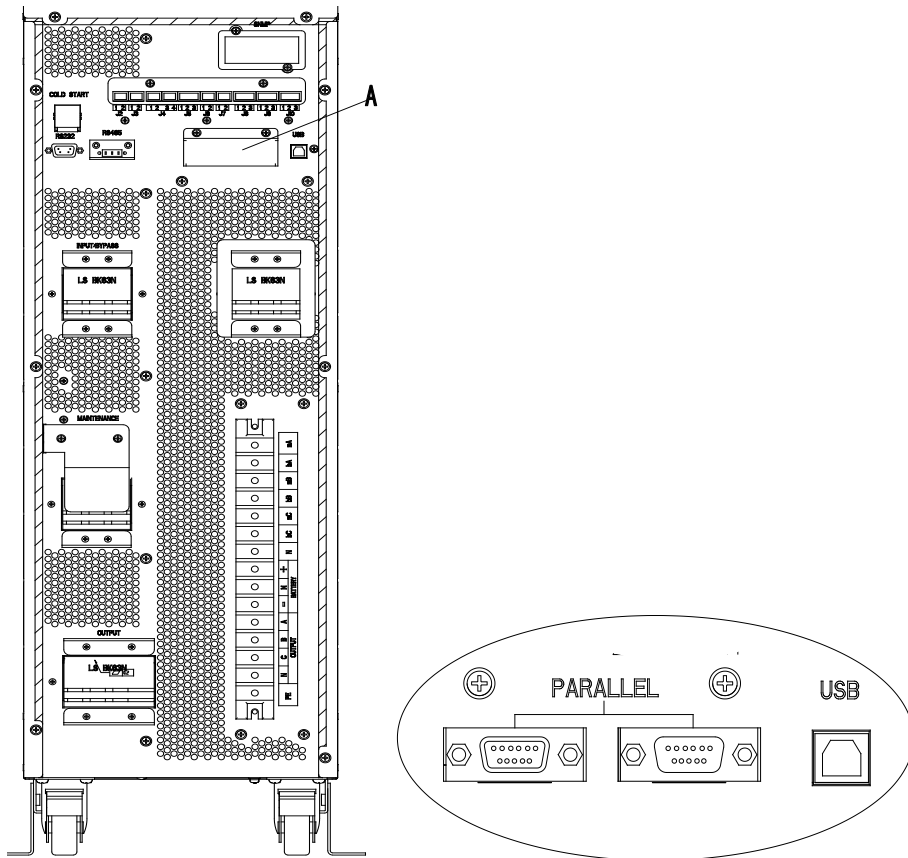

Fig.5-7 Location of the Parallel board

All the parallel cables are designed to be shielded, double insulated and are connected between the UPS to form a loop as shown below in Fig.5-8.

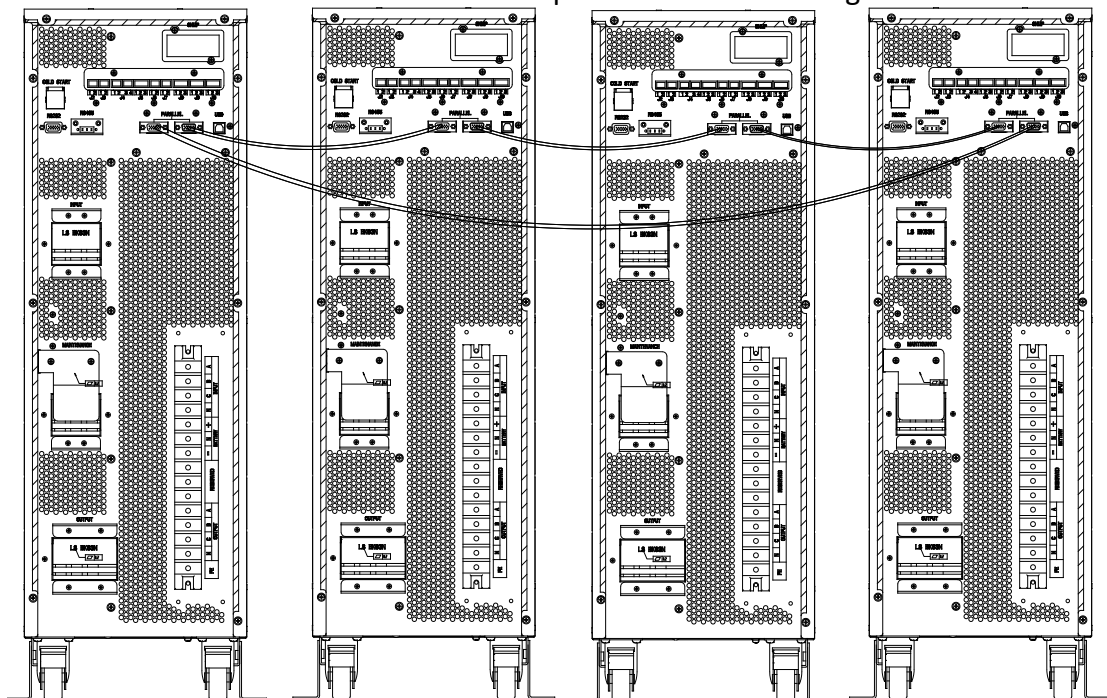

Fig.5-8 Parallel connection

5.5.2 Parallel system setting

Parallel system connection

For field installation please connect the cables according to Fig.5-6 and Fig.5-8. In order to assure that all units are equally utilised and to comply with relevant wiring rules the following requirements apply:

1. All units shall be of the same rating and must be connected to the same bypass source.
2. The bypass and the main input sources must be referenced to the same neutral potential.
3. Any RCD (Residual Current Detecting device), if installed, must be of an appropriate setting and located upstream of the common neutral bonding point. Alternatively the device must monitor the protective earth currents of the system. Refer to the High Leakage Current Warning in the first part of this manual.
4. The outputs of all UPS must be connected to a common output bus.

Parallel system software setting

To change the parallel system settings please follow the steps below.

1. With the monitoring software from manufacturer select the page of “Service Setting” as below,

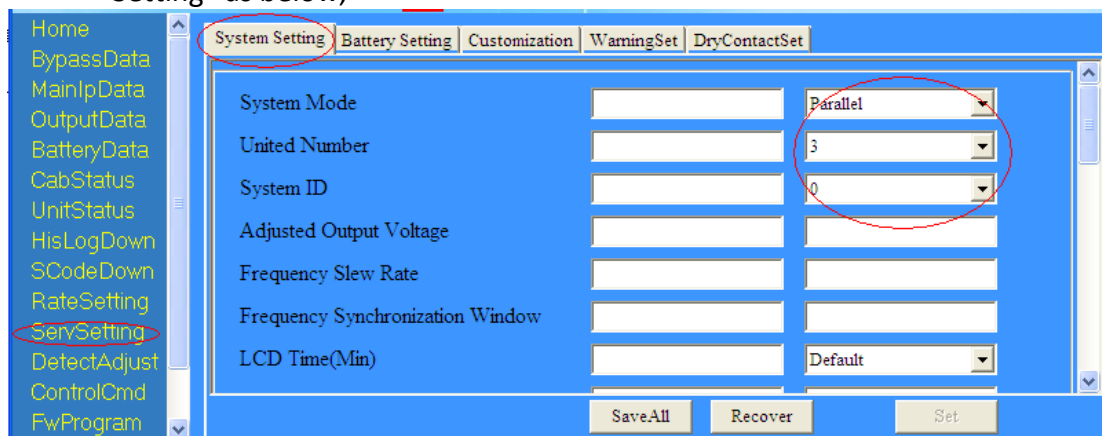

Set “System Mode” to “Parallel” and set the “United Number” to the number of units in parallel. For the setting of system ID with a system of 3 units in parallel for example, set the number from 0 to 2 for these 3 units accordingly. Restart the UPS when finished and press the “Set” button. Ensure all the output parameters are set the same.

Parallel system jumper setting

There are different settings for the jumpers on the parallel board and control board for different parallel systems. The location of connectors on parallel board is shown in Fig. 5-11 and control board in Fig. 5-12.

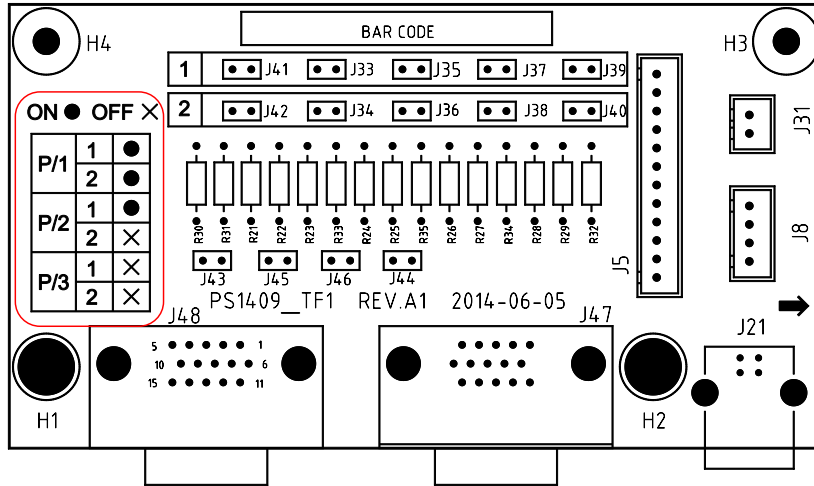

Fig.5-11 Connectors on Parallel board (PS1409_TF1)

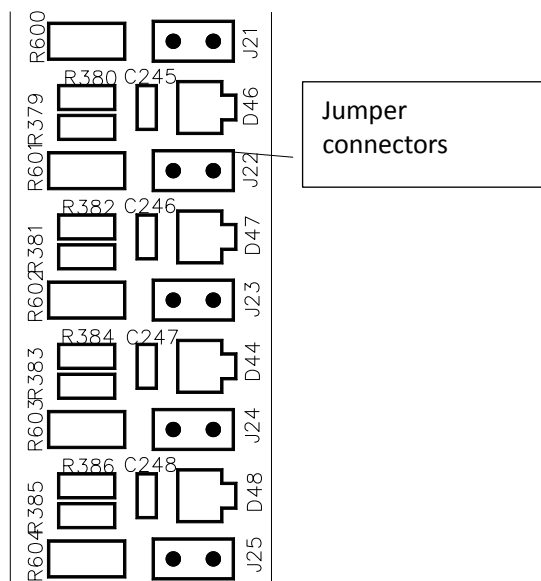
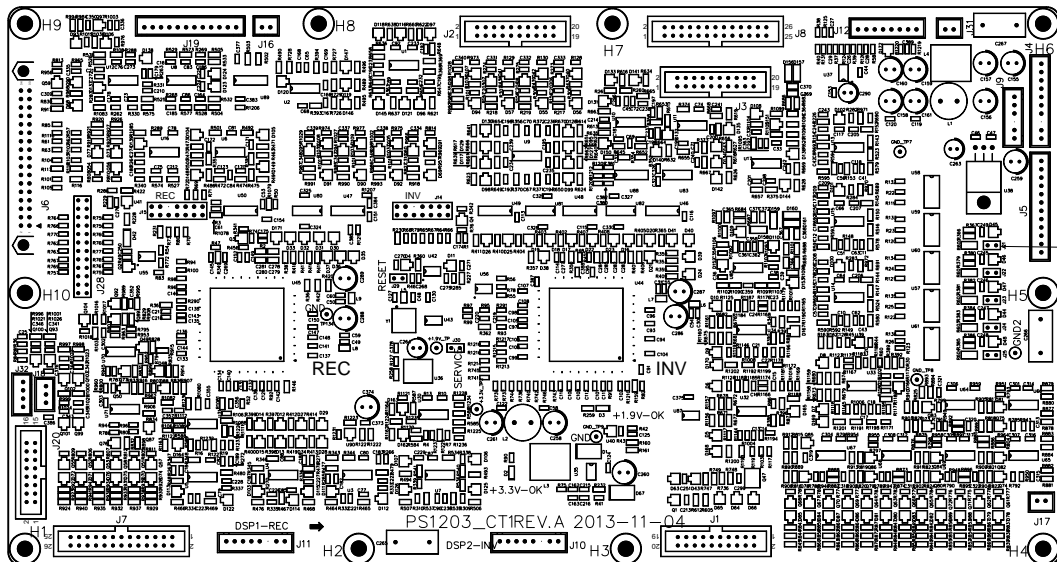

Fig.5-12 Connectors on Control board (PS1203_CT1)

1. Parallel boards settings

- A. For single UPS a parallel board is not needed. When a parallel board is installed connectors J33 to J42 should be bridged by jumpers.
- B. For 2 UPS solutions in parallel, short the connectors of J33/J35/J37/J39/J41 by jumpers on each board, keep connectors of J34/J36/J38/J39/J42 open.
- C. For 3 or 4 UPS solutions in parallel keep connectors of J33-J42 open.

2. Control boards settings

The control board is named PS1203_CT1.

For single UPS keep the J21-J25 shorted by jumpers

For parallel, keep all the connectors J21-J25 open. As shown in Fig. 5-12.

Note: Connectors not mentioned must be untouched.

When all the connections and settings are finished, follow the steps below for the operation of parallel system setup.

1. Close the output and input breaker of the first unit. Wait for the startup of bypass static switch and rectifier, about 90s later the system will transfer to normal mode. Check if there is an alarm on the LCD and verify the output voltage is correct.
2. Turn on the second unit in the same method as the first, the unit will join the parallel system automatically.
3. Turn on the rest units one by one and check the information on the LCD.
4. Verify the load sharing.

6. Maintenance

This chapter introduces UPS maintenance, including the maintenance instructions of the power module and monitoring bypass module as well as the replacement method for the dust filter.

6.1 Precautions

1. Only certified engineers are authorised to maintain the UPS.
2. The components or PCBs should be disassembled from top to bottom so as to prevent any inclination from high center of gravity in the cabinet.
3. To ensure safety before maintaining, measure the voltage between operating parts and the earth with a multimeter to ensure the voltage is lower than hazardous voltage, i.e. DC voltage is lower than 60VDC, and AC maximum voltage is lower than 42.4VAC.
4. Wait 10 minutes before opening the cover of the power module or the bypass after removing from the UPS.

6.2 Instructions for maintaining UPS

For the maintenance of the UPS, please refer to chapter 5.2.4 for the instruction to transfer to maintenance bypass mode. After maintenance transfer back to normal mode according to chapter 5.2.5.

6.3 Instruction for maintaining battery string

For the Lead-Acid maintenance free battery correct maintaining the batteries can prolong their life. The battery life is mainly determined by the following factors:

1. Installation. The battery should be placed in dry and cool location with good ventilation. Avoid direct sunlight and keep away from heat sources. When installing batteries, ensure you connect only batteries of the same specification and age.
2. Temperature. The most suitable storage temperature is 20°C-25°C. Battery life will be shortened if the battery is used under high temperature or in a deep discharge. Refer to the product manual for details.
3. Charging/discharging current. The best charging current for the lead-acid battery is 0.1C. The maximum current for the battery can be 0.3C. The suggested discharging current is between 0.05C-3C.
4. Charging voltage. Most of the time the battery is in standby. When the utility is normal the system will charge the battery in boost mode (Constant voltage with maximum limited) to full capacity and then transfers to the state of float charge.
5. Discharge depth. Avoid deep discharges which will greatly reduce the life time of the battery. When the UPS runs in battery mode with light load or no load for a long time it will cause the battery to deep discharge.
6. Check periodically. Check for any abnormality of the battery and measure if the voltage of each battery is in balance as well as discharging the battery periodically. Contact your CertaUPS Partner for this service.



Warning

Daily inspection is very important!

Check and confirm the battery connection is tightened regularly, and make sure there is no abnormal heat generated from the battery.



Warning

If a battery has leaked or is damaged it must be replaced and stored in a container resistant to sulfuric acid. Dispose of in accordance with local regulations.

The waste lead-acid battery is a kind of hazardous waste and is one of the major contaminants controlled by regulation. Therefore, its storage, transportation, use and disposal must comply with the national regulations and laws about the disposal of hazardous waste and waste batteries. According to national law the waste lead-acid batteries should be recycled and reused and it is prohibited to dispose of batteries in other ways except recycling. Throwing away the waste lead-acid batteries through improper disposal methods will cause severe environment pollution and the person who does this will bear the corresponding legal responsibilities.

6.2.4 Installation of internal battery

For 10kVA to 40kVA internal battery UPS the internal batteries and the cables within the battery string are not provided as standard. If required, please contact your local CertaUPS agent.

For 10-15kVA UPS, 40 x 7Ah/9Ah batteries can be installed internally.

For 20-30kVA UPS, 40 x 12Ah batteries can be installed internally.

For 40kVA UPS, 80 x 12Ah batteries can be installed.

For 10-15kVA UPS, there are 40 batteries to be installed which are divided into 4 layers. Fig. 6-1 shows the installation of battery of the 10-15kVA standard UPS.

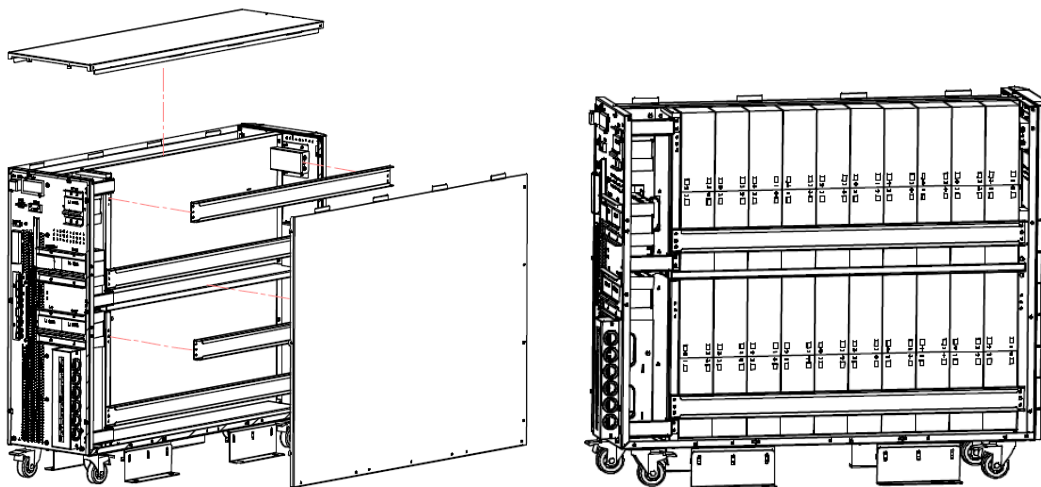

1. Dismantle the covers and crossbeams
2. Install battery and fix the crossbeams

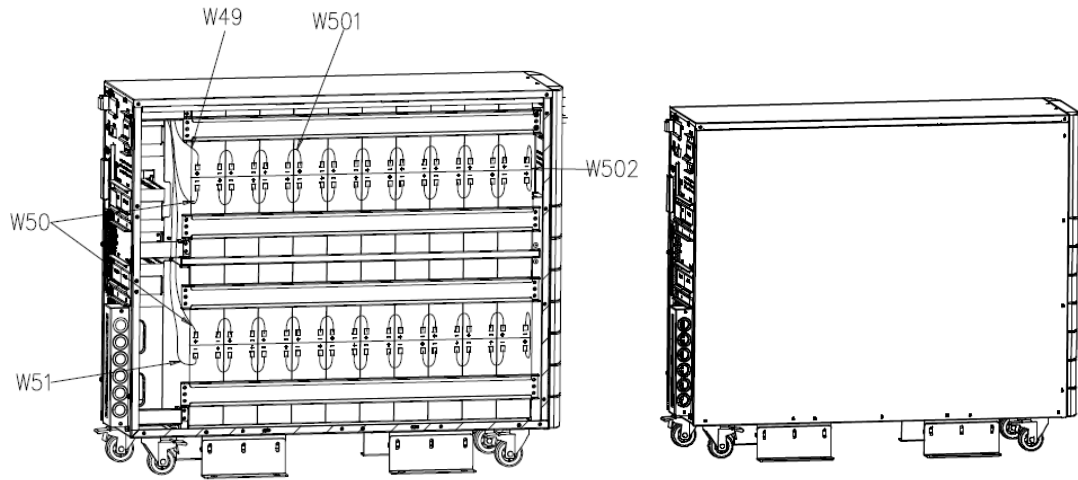

3. Connect the battery cable according to the series number 4. Recover the cover

Fig.6-1 Installation of inner battery for 10, 15kVA internal battery UPS

Fig. 6-2 shows the installation of batteries for 20-30kVA standard UPS. There are 8 groups of batteries in series, with 5 cblocks for each group. The interconnection among groups is via cable with Anderson Socket.

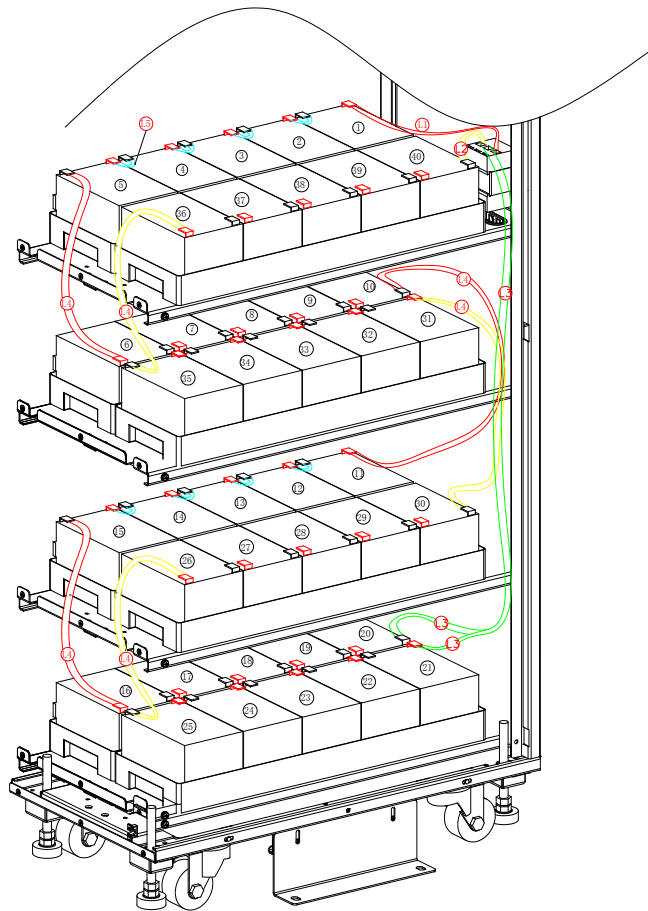

Fig.6-2-1 Cable interconnection of the battery string

Layer 1. The positive of the battery 1# is connected to battery breaker CB4-2, via the cable labeled L1, and the negative of battery 40# is connected to CB4-6, via the cable labeled L2, as shown in Fig. 6-2-2.

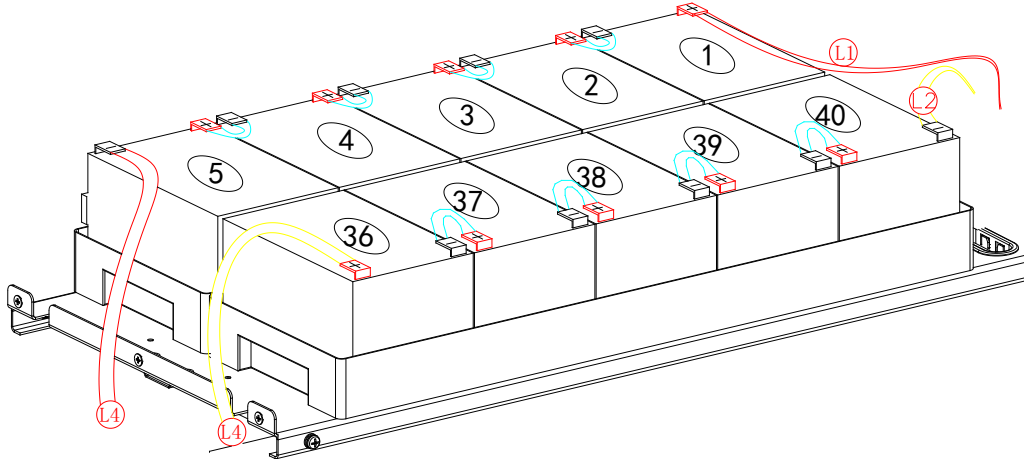

Fig.6-2-2 Cable connection of Lay 1

Layer 2. The positive of the battery 6# is connected to the negative of battery 5#, via the cable labeled L4, and the negative of battery 35# is connected to the positive of battery 36#, via the cable labeled L4, as shown in Fig.6-2-3.

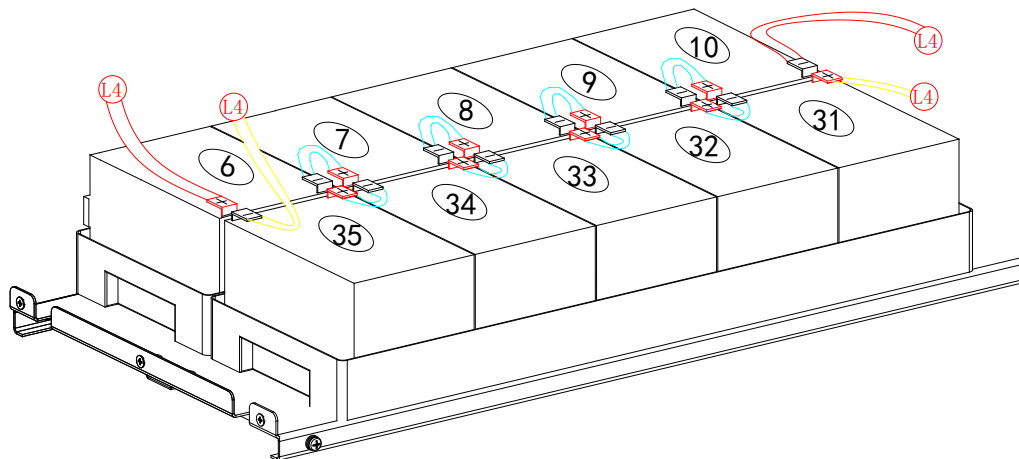

Fig.6-2-3 Cable connection of Lay 2

Layer 3. The positive of the battery 11# is connected to the negative of battery 10#, via the cable labeled L4, and the negative of battery 30# is connected to the positive of battery 31#, via the cable labeled L4, as shown in Fig.6-2-4.

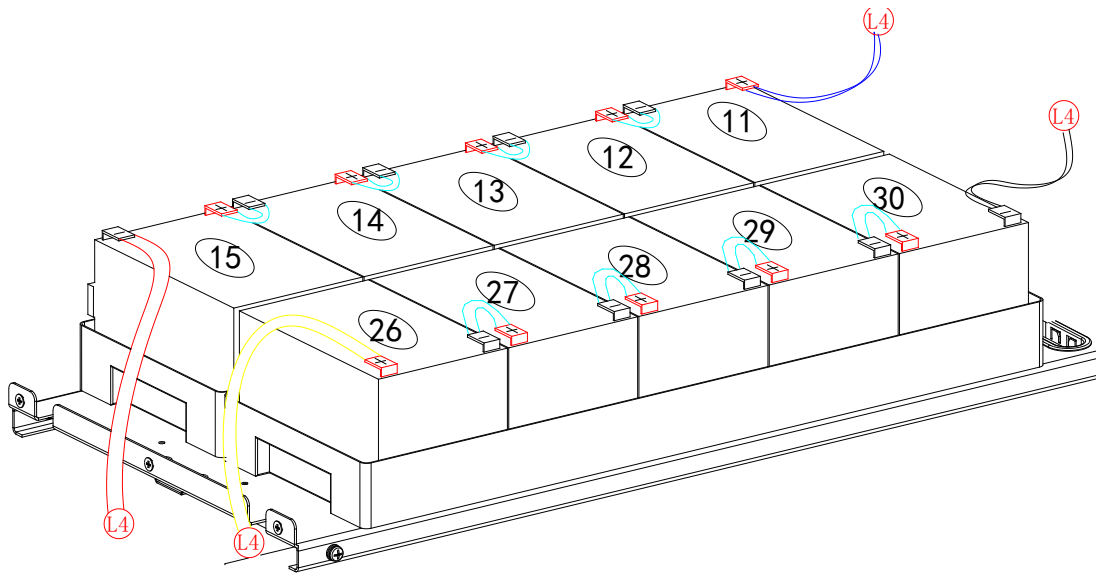

Fig.6-2-4 Cable connection of Lay 3

Layer 4. The positive of the battery 16# is connected to the negative of battery 15#, via the cable labeled L4, and the negative of battery 25# is connected to the positive of battery 26#, via the cable labeled L4. The negative of 20# and the positive of 21#, which are defined as the battery neutral, are connected to CB4-4, as shown in Fig.6-2-5.

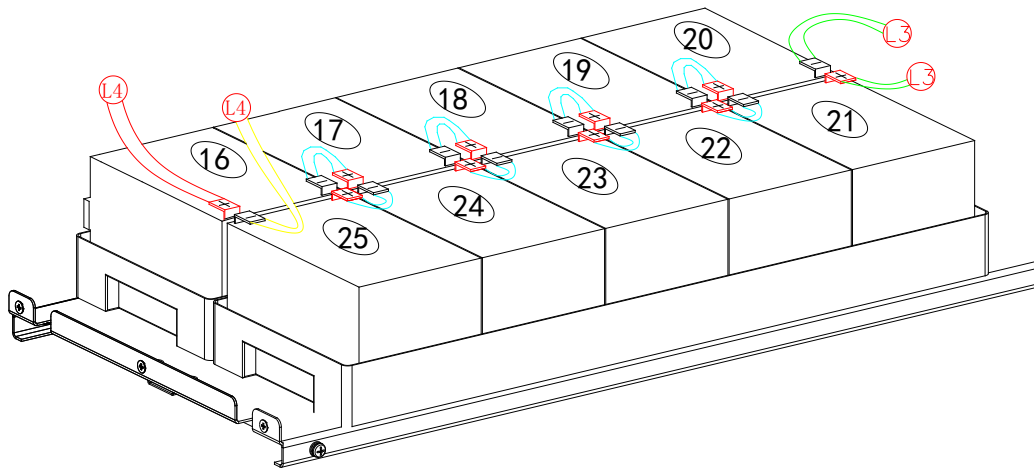

Fig.6-2-5 Cable connection of Lay 4

Fig.6-2 Installation of inner battery for 20, 30K standard UPS

For the 40kVA, the battery bank has four layers. Each lay has four packages with 5 batteries contained in one package. Fig. 6-3 shows the connection of each layer.

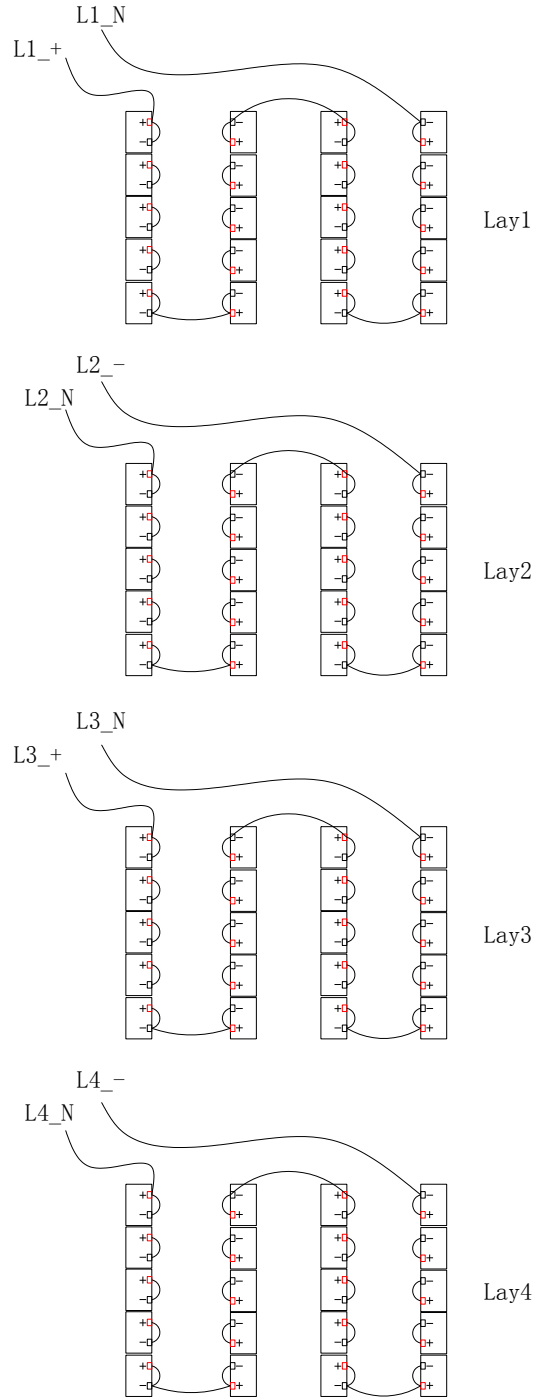

Fig. 6-3 battery connection of each layer

Fig. 6-3 Connection between layers (Connect according to the serial number)

After the completing connections as shown in Fig. 6-3, connect the connectors as following as shown within zoomed in fig. 6-4

Terminal+: L1_+ and L3_+

Terminal N: L1_N, L2_N, L3_N, L4_N,

Terminal-: L2_- and L4_-

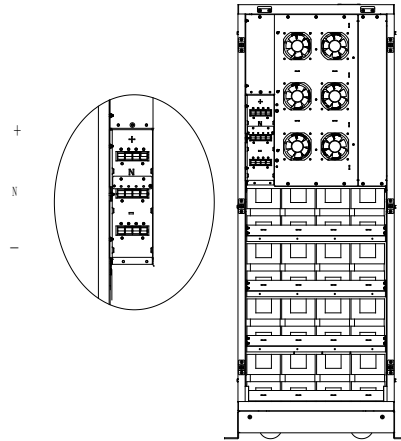

Figure 6-4 Battery terminal connection

After connecting the terminal, replace the cover as shown in the following fig. 6-5

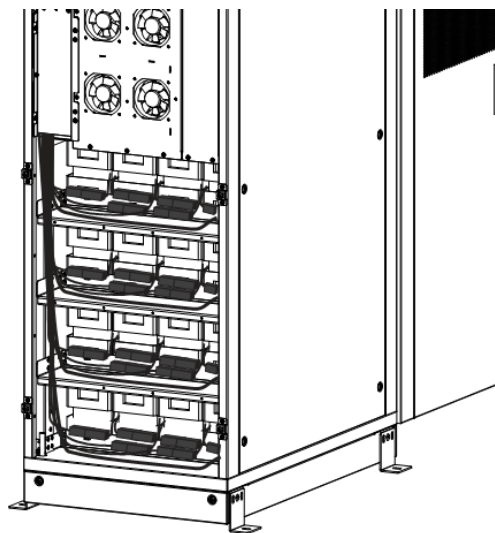

Fig 6-5,Recover the cover



Warning

*Make sure the polarity of the battery is correct according to the diagrams above.
Test and confirm the battery voltage before connecting to the main circuit.*

7. Product Specification

This chapter provides the specifications of the product including environmental, mechanical and electrical characteristics.

7.1 Applicable Standards

The UPS has been designed to conform to the following European and international standards:

Table 7.1 Compliance with European and International Standards

Item	Normative reference
General safety requirements for UPS used in operator access areas	EN50091-1-1/IEC62040-1-1/AS 62040-1-1
Electromagnetic compatibility (EMC) requirements for UPS	EN50091-2/IEC62040-2/AS 62040-2 (C3)
Method of specifying the performance and test requirements of UPS	EN50091-3/IEC62040-3/AS 62040-3 (VFI SS 111)



Note

The above mentioned product standards incorporate relevant compliance clauses with generic IEC and EN standards for safety (IEC/EN/AS60950), electromagnetic emission and immunity (IEC/EN/AS61000 series) and construction (IEC/EN/AS60146 series and 60950).



Warning

This product conforms the EMC requirements for UPS in Category C3. Where used for medical or life critical applications it should only be done so in accordance with legal & best practice regulations.

7.2 Environmental Characteristics

Table 7.2 Environmental Characteristics

Item	Unit	Requirements
Acoustic noise level at 1 meter	dB	58dB @ 100% load, 55dB @ 45% load
Altitude of Operation	m	≤1000, load derated 1% per 100m from 1000m and 2000m
Relative Humidity	%	0-95%, non condensing
Operating Temperature	°C	0-40°C, Battery life is halved for every 10°C increase above 20°C
UPS Storage Temperature	°C	-40-70°C

7.3 Mechanical Characteristic

Table 7.3 Mechanical Characteristics for Cabinet

Model	Unit	C800-10/15-C	C800-10/15-B	C800-20/30-b	C800-20/30-C	C800-40-C	C800-40-B
Dimension W×D×H	mm	250*660*530	250*840*715	350*738*1335	250*680*770	250*836*770	500*840*1400
Weight	kg	28	50	88	50	61	140
Color	N/A	BLACK, RAL 7021					
Protection Level IEC (60529)	N/A	IP20					

7.4 Electrical Characteristics

7.4.1 Electrical Characteristics (Input Rectifier)

Table 7.5 Rectifier AC input Mains

Item	Unit	Parameter
Grid System	\	3 Phases + Neutral + Ground
Rated AC Input Voltage	VAC	380/400/415 (three-phase and sharing neutral with the bypass input)
Rated Frequency	VAC	50/60Hz
Input Voltage Range	VAC	304~478 VAC (Line-Line),full load 228V~304 VAC (Line-Line),load decrease linearly according to the min phase Voltage
Input Frequency Range	Hz	40~70
Input Power Factor	PF	>0.99
THDI	THDI%	<3% (full Linear Load)

7.4.2 Electrical Characteristics (Intermediate DC Link)

Table 7.6 Battery

Items	Unit	Parameters
Battery bus voltage	VDC	Rated: ±240V
Quantity of lead-acid Batteries	Nominal	40=[1 battery(12V)] ,240=[1 battery(2V)]
Float charge Voltage	V/cell (VRLA)	2.25V/cell(selectable from 2.2V/cell~2.35V/cell) Constant current and constant voltage charge mode
Temperature Compensation	mV/°C/cI	3.0(selectable:0~5.0)
Ripple voltage	%	≤1
Ripple Current	%	≤5
Equalized charge Voltage	VRLA	2.4V/cell(selectable from : 2.30V/cell~2.45V/cell) Constant current and constant voltage charge mode
Final discharging Voltage	V/cell (VRLA)	1.65V/cell(selectable from: 1.60V/cell~1.750V/cell) @0.6C discharge current 1.75V/cell (selectable from: 1.65V/cell~1.8V/cell) @0.15C discharge current (EOD voltage changes linearly within the set range according to discharge current)
Battery Charge	V/cell	2.4V/cell(selectable from : 2.3V/cell~2.45V/cell) Constant current and constant voltage charge mode
Battery Charging Power Max Current	kW	10%* UPS capacity (selectable from : 1~20% * UPS capacity)

7.4.3 Electrical Characteristics (Inverter Output)

Table 7.7 Inverter Output (To critical load)

Item	Unit	Value
Rated Capacity	kVA	10/15/20/30/40
Rated AC voltage	VAC	380/400/415 (Line-Line)
Rated Frequency	Hz	50/60
Frequency Regulation	Hz	50/60Hz±0.1%
Voltage Precision	%	±1.5(0~100% linear load)
Overload	\	110%, 60min; 125%,10min; 150%,1min; >150%,200ms
Synchronized Range	Hz	Settable, ±0.5Hz ~ ±5Hz, default ±3Hz
Synchronized Slew Rate	Hz	Settable, 0.5Hz/s ~ 3Hz/s, default 0.5Hz/s
Output Power Factor	PF	1.0 (10-15kVA), 0.9 (20-40kVA)
Transient Response	%	<5% for step load (20% - 80% -20%)
Transient Recovery		< 30ms for step load (20% - 100% -20%)
Output Voltage THDu		<1% from 0% to 100% linear load <6% full non-linear load according to IEC/EN62040-3

7.4.4 Electrical Characteristics (Bypass Mains Input)

Table 7.8 Bypass Mains Input

Item	Unit	Value
Rated AC Voltage	VAC	380/400/415 (three-phase four-wire and sharing neutral with the bypass)
Overload	%	125% Long term operation; 125%~130% for 10min; 130%~150% for 1min; 150%~400% for 1s; >400% ,less than 200ms
Current Rating Of Neutral Cable	A	1.7×In
Rated Frequency	Hz	50/60
Switch Time (Between Bypass and Inverter)	ms	Synchronized transfer: 0ms
Bypass Voltage Range	%	Settable, default -20%~+15% Upper limit: +10%, +15%, +20%, +25% Lower limit: -10%, -15%, -20%, -30%, -40%
Bypass Frequency Range	Hz	Settable, ±1Hz, ±3Hz, ±5Hz
Synchronized Range	Hz	Settable ±0.5Hz~±5Hz, default ±3Hz

7.5 Efficiency

Table 7.9 Efficiency

Rated power (kVA)	Unit	10/15kVA	20/30kVA	40kVA
Overall efficiency				
Online mode(dual conversion)	%	>95	>95	>96
Battery discharging efficiency (battery at nominal voltage 480VDC and full-rated linear load)				
Battery mode	%	>94.5	>95	>96

7.6 Display and Interface

Table 7.10 Display and Interface

Display	LED + LCD
Interface	Standard: RS232, RS485 Option: SNMP ,Dry Contact